

shindaiwa®

OPERATOR'S MANUAL POWERCENTER 15



CE



CAUTION

Do not operate the Generator, or any other appliance, before you have read and understood the instructions for use.

Table of Contents

Introduction	1
EC Declaration of Conformity	2
1. Safety Guidelines	3
2. Specifications	9
2-1. Specifications	9
2-2. Ambient Conditions	9
3. Applications	9
4. Parts	10
5. Equipment	13
5-1. Spill Containment	13
5-2. Multi digital meter	13
5-3. Error Code Display	14
5-4. Monitor Lamp	14
5-5. Earth Leakage Circuit Breaker and Grounding	16
5-6. Emergency Stop Switch	19
5-7. Terminal Cover Switch	19
6. Load connections	20
6-1. Load Cable Selection	20
6-2. Connecting Load Cable	21
7. Pre-Operation Inspection	25
7-1. Engine Oil Inspection	25
7-2. Cooling Water Inspection	26
7-3. Fuel Inspection	27
7-4. Spill Containment Inspection	27
7-5. Inspection for Fuel/Oil/Cooling Water Leakage	28
7-6. Battery Inspection	28
8. Operating Procedures	29
8-1. Initial Startup/Pre-Check	30
8-2. Stopping Operation	32
8-3. Protective Functions	33
9. Inspection/Maintenance	34
10. Long-Term Storage	41
11. Troubleshooting	42
12. Engine Wiring Diagram	44
13. Generator Wiring Diagram	45

Introduction

Thank you for purchasing a Shindaiwa Sound Proof Diesel Engine Generator.

- This operation manual has been created to ensure the safe operation of this equipment. Therefore, the manufacturer of this equipment strongly recommends that the user follow the instructions herein, to avoid unnecessary accidents and repairs.
- Please operate this equipment after thoroughly reviewing and understanding the contents of this manual.
- Please supply this manual with the equipment.

■ The following conventions will be used throughout the manual to indicate the degree of caution.

⚠ Warning	Can cause serious injuries or death.
⚠ Caution	Can cause minor injuries or damage to the equipment or other properties.
<Caution>	Other types of caution

- Even some of the items noted in 『**⚠ Caution**』 may lead to serious injuries. Please read all items and follow all the safety guidelines.

The following statement refers to the noise level data contained in the **EC Declaration of Conformity** contained on page 2 of this manual:

“The figures quoted are emission levels and are not necessarily safe working levels. Whilst there is a correlation between the emission and exposure levels, this cannot be used reliably to determine whether or not further precautions are required. Factors that influence the actual level of exposure of work-force include the characteristics of the work place, the other sources of noise, etc. i.e. the number of machines and other adjacent processes, and the length of time for which an operator is exposed to the noise. This information, however, will enable the user of the machine to make a better evaluation of the hazard and risk”.

EC Declaration of Conformity

In accordance with EN ISO 17050-1:2004

We

Shindaiwa Ltd

of

Unit 6 The Dell, Enterprise Drive, Four Ashes, Wolverhampton WV10 7DF

in accordance with the following Directives:

- 2004/108/EC The Electromagnetic Compatibility Directive
and its amending directives
- 2006/42/EC The Machinery Directive
- 2000/14/EC The Noise Emission in the Environment by Equipment for Use Outdoors Directive
- 2011/65/EU The Restriction of Hazardous Substances Directive

hereby declare that:

Equipment Engine driven generator
Model number PowerCenter 15
Serial Number(s) W0165500581

is in conformity with the applicable requirements of the following documents

Ref. No.	Title	Edition/date
BS EN ISO 12100	Safety of machinery. General principles for design. Risk assessment and risk reduction	2010
BS EN 60204-1	Safety of machinery. Electrical equipment of machines. General requirements	2006 +A1:2009
BS EN 61000-6-2	Electromagnetic compatibility - immunity	2005
BS EN 61000-6-4	Electromagnetic compatibility - emissions	2007
BS EN 12601	Reciprocating internal combustion engine driven generating sets. Safety	2010

Noise measurements have been made in accordance with ISO 3744 with internal control of production (Schedule 8/Annex V). The declared noise values are as follows:

Measured sound power level	Guaranteed sound power level
(90) dB L _{wa}	(92) dB L _{wa}

I hereby declare that the equipment named above has been designed to comply with the relevant sections of the above referenced specifications. The unit complies with all applicable Essential Requirements of the Directives.

Signed by:

Name: D.Richards

Position: Director

Done at Wolverhampton

On 10/04/14



Document ref. No.
PC1500001

The technical documentation for the machinery is available from the manufacturer at the above address.

1. Safety Guidelines

⚠ Warning: Suffocation from Exhaust Fumes

- Do not operate the equipment in a poorly-ventilated area such as indoors or within a tunnel because the engine exhaust fume includes components that are harmful to humans.

⚠ Warning: Electric Shock

- Do not operate the equipment with any doors or covers open.
- Do not touch wirings or any electric parts inside the equipment during operation.
- Do not touch the equipment during operation if the equipment or your body is wet.
- Be sure to stop the engine whenever touching output terminals such as when installing or removing cables.
- Do not connect cables to any part other than output terminals.
- Do not insert any metallic objects, such as pins or wires, into AC output receptacles or terminals.
- Always be sure to turn off all breakers before installing or removing devices using AC output receptacles.
- Always be sure to repair the corresponding earth leakage location when earth leakage circuit breakers operate.
- Always be sure to stop the engine and remove the starter key before performing any equipment check or maintenance.
- This machine is rated to IP23.

⚠ Warning: Fire

- Always be sure to stop the engine when inspecting fuel or refueling, and absolutely never perform such tasks near fire or other open flame. Wait until the engine has completely cooled before inspecting fuel or refueling.
- Always be sure to wipe up any spilled fuel or oil.
- Spilled fuel and oil accumulates in the spill containment. Do not operate the equipment with liquid accumulated in the spill containment.
- Absolutely never use the equipment if there is a fuel, oil or cooling water leak, and be sure to always repair the leak before using.
- Absolutely never inspect or perform maintenance to the equipment near fire or other open flame.
- Keep any ignitable items (such as fuel, gas and paint) or inflammable items away from the equipment because the muffler, exhaust fume and other parts attain high temperatures.
- Provide at least 1 meter (3 feet) of distance between the equipment and walls and other obstacles, and operate the equipment on a flat surface.
- Allow the equipment to cool before covering with protective covers and similar items.
- Do not ground wiring of earth leakage circuit breakers of the equipment to piping that passes through flammable material.

⚠ Warning: Injuries

- Do not operate the equipment with any doors or covers open. There is a danger of hair, body parts and other items being caught up in moving parts such as cooling fans and belts.
- Do not modify the equipment and do not operate with parts removed.
- Always be sure to stop the engine and remove the starter key before performing any equipment check or maintenance.

⚠ Warning: Injuries to Eyes and Skin

- Use protective gear, such as rubber gloves, when inspecting or replacing the battery due to the dilute sulfuric acid in the battery fluid. Be sure that fluid does not get into eyes, or on skin or clothing.
- If battery fluid gets into the eyes, or on the skin or clothing, immediately wash with a large amount of water, and always be especially sure to seek medical attention if it gets into the eyes.

⚠ Warning: Explosion

- Do not operate the equipment or recharge the battery when the battery fluid level is below the lower level.
- Do not generate any sparks near the battery and do not allow any fire or other open flame near the equipment because the battery generates ignitable gas.

⚠ Warning: Electromagnetic Interference

- Persons using a heart pacemaker are not allowed near the Generator work area while Generator is being performed without the permission of a doctor. The welder generates a magnetic field while energized that can negatively affect pacemaker operation.

⚠ Caution: Suffocation from Exhaust Fumes

- Do not direct the engine exhaust towards passersby, private homes or similar persons/locations because the engine exhaust fume includes components that are harmful to humans.

⚠ Caution: Electric Shock

- Do not sprinkle water on the equipment and do not use where exposed to rain.
- If wearing gloves, be sure to always wear gloves with dry insulation properties. Do not wear gloves that are damaged or wet.

⚠ Caution: Burns

- The engine, muffler and similar parts are extremely hot during operation and immediately after stopping the equipment. Never touch hot parts.
- Never open the radiator cap during operation or immediately after stopping the equipment. Hot cooling water and steam will spurt out.
- Always be sure to stop the engine and allow it to cool before inspecting or changing the engine oil. Opening the oil gauge or oil plug during operation will result in hot oil spurting out.

⚠ Caution: Injuries

- Use this equipment with it situated on a stable level surface so that it is prevented from moving.
- Do not move the equipment during operation.
- Always be sure to turn off the switches of all devices using the equipment and turn off the equipment breakers before starting the engine.
- Always be sure to turn off the power switches of all devices using the equipment when turning on the equipment breakers. Leaving on the power switch of a device using the equipment when the equipment breakers are turned on could result in the sudden operation of the corresponding device.
- Do not leave on the power switch of a device using the equipment and do not connect a device to an AC output receptacle.
- The lifting lug is designed to be used only for lifting the equipment. Do not lift the equipment with any heavy items (such as a trailer and additional fuel tank) added to the equipment.
- Always be sure to use the lifting lug when lifting the equipment, and lift slowly and directly straight above.
- Wear a helmet, safety shoes, gloves and similar protective gear when performing lifting work. Do not stand or get under the equipment while it is suspended.
- Securely fix the equipment with rope or similar item so that it cannot move when transporting by truck or other vehicle.

⚠ Caution: Physical and Secondary Damage

- Do not use the equipment for any improper applications. Improper usage can result in an accident or malfunction.
- Do not connect the AC power source to indoor wiring.
- If using the equipment as a power source for medical equipment, you must check with the medical equipment manufacturer, doctor and hospital before using the equipment.

■ Location of Warning Labels

Replace warning labels when they become difficult to see or damaged by affixing new labels in the specified locations. Order the necessary labels by numbers in parentheses.

- (1) Fire (No. X505-007650)
- (2) Suffocation from exhaust fume (No. X505-007570)
- (3) Lifting eye (No. X505-000240)
- (4) Hot surface (X505-006420)
- (5) Burns (No. X505-006410)
- (6) Keep 1 meter (No. M707-000260)
- (7) Injuries (No. X505-007630)
- (8) Electric shock (No. X505-007560)
- (9) Earth leakage relay (No. X505-004890)
- (10) Positioning handle (No. X505-006430)

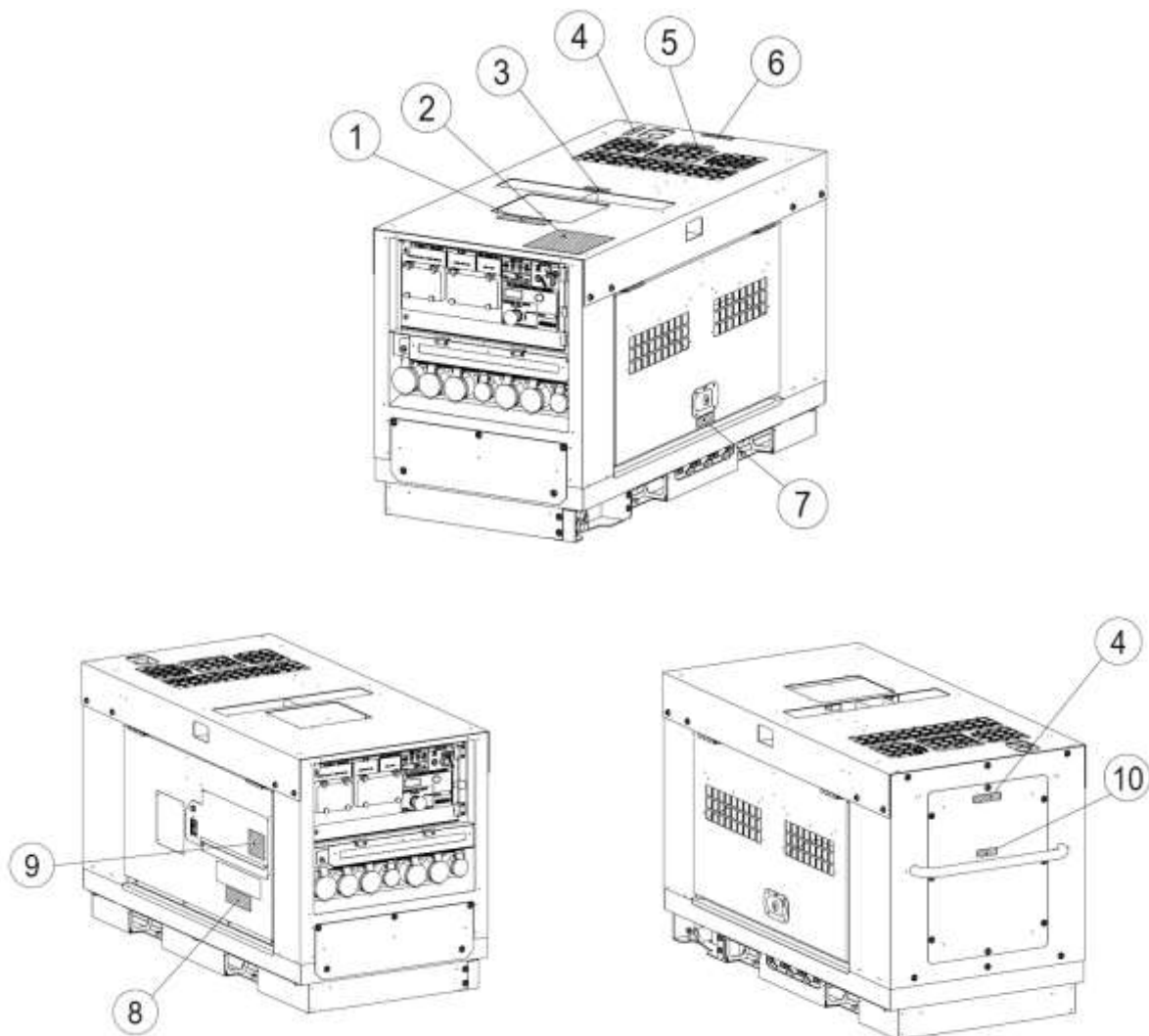

LABEL REPRODUCTION

① X505-007650



② X505-007570



③ X505-000240



④ X505-006420



⑤ X505-006410



⑥M707-000260



⑦X505-007630



⑧X505-007560

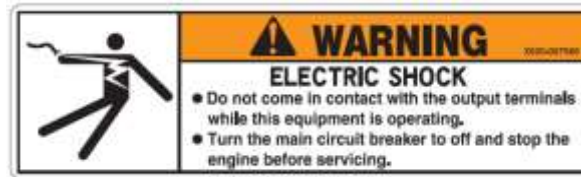

⑨X505-004890

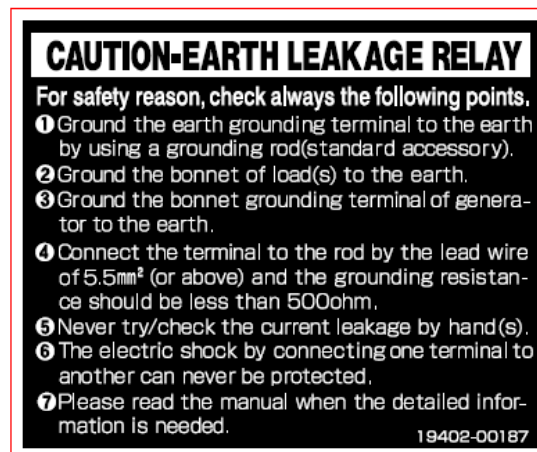

⑩X505-006430



2. Specifications

2-1.Specifications

Model		POWERCENTER15		
Generating Method		Rotating Field		
AC Generator	Rated Frequency (Hz)	50		
	Rated Speed (min ⁻¹)	3000		
	Phase	3-Phase	1-Phase	
	Rated Voltage (V)	415	240	110
	Rated Current (A)	21	50	110
	Power Factor	0.8	1.0	
	Rated Output (kVA)	15	12	
	Rating	Continuous		
Engine	Model	Kubota D902		
	Type	Vertical, Water-Cooled 4-Cycle Diesel Engine		
	Displacement (L)	0.898		
	Rated Output (kW/min ⁻¹)	13.1/3000		
	Fuel	ASTM No.2-D Diesel Fuel or Equivalent		
	Lubricant Oil	API Class CD or Higher		
	Lubrication Oil Volume (L)	3.6 (Effective 1.7)		
	Cooling Water Volume (L)	4.0 (Sub Tank Capacity 0.6 L included)		
	Starting Method	Starter Motor		
Battery		46B24L (Japanese Industrial Standard)		
Fuel Tank Capacity (L)		37		
Dimension	Length (mm)	1344		
	Width (mm)	640		
	Height (mm)	778		
Dry Weight (kg)		387		

Generating Set ISO 8528-8/G2 EMC Group 2 class A

2-2.Ambient Conditions

- Temperature : -15~40°C
- Humidity : 80% or less
- Elevation : 300m or less

3. Applications

- Power Source for Light, Electric Tools and Appliances

⚠ Caution: Physical and Secondary Damage

- Do not use the equipment for any applications not listed above. Improper usage can result in an accident or malfunction.
- If using the equipment as a power source for medical equipment, you must check with the medical equipment manufacturer, doctor and hospital before using the equipment.

4. Parts

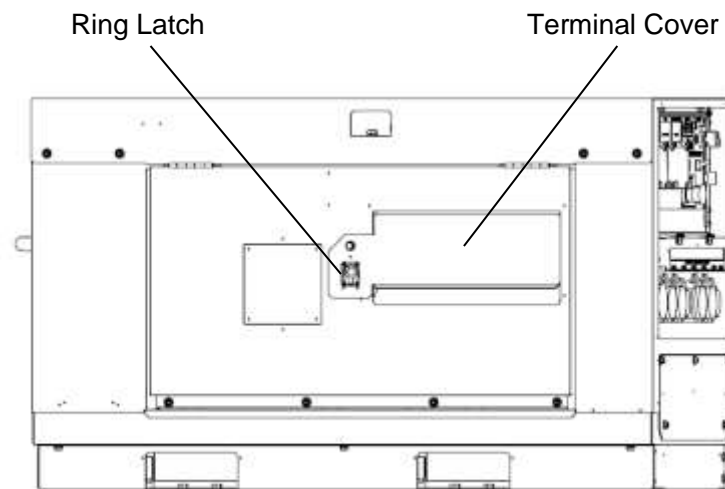
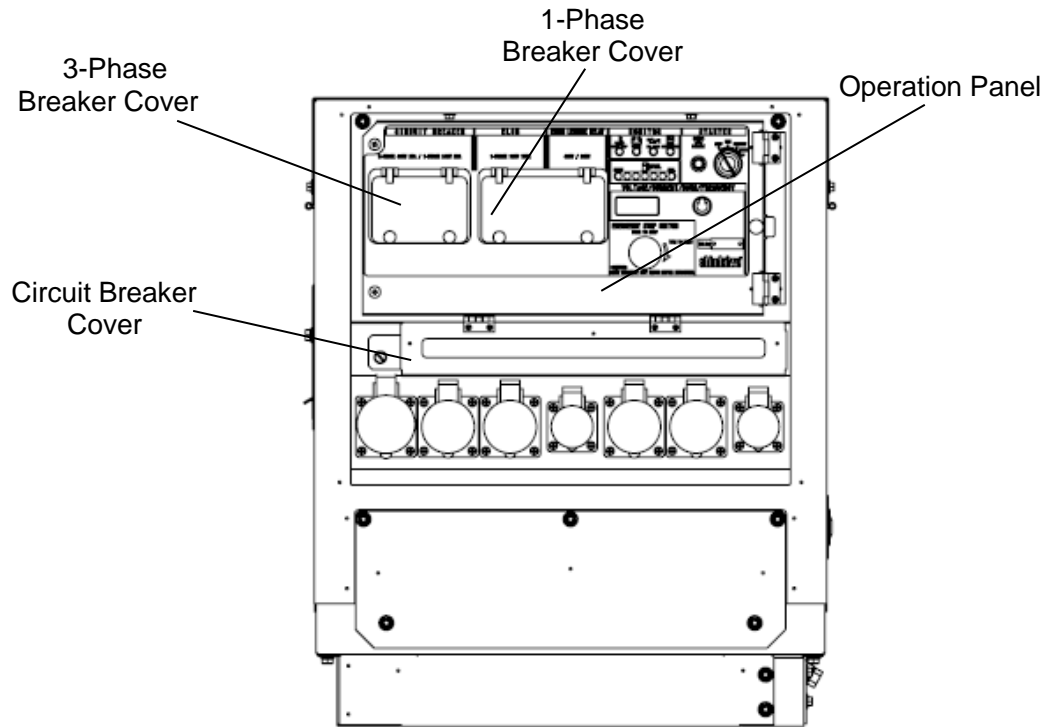

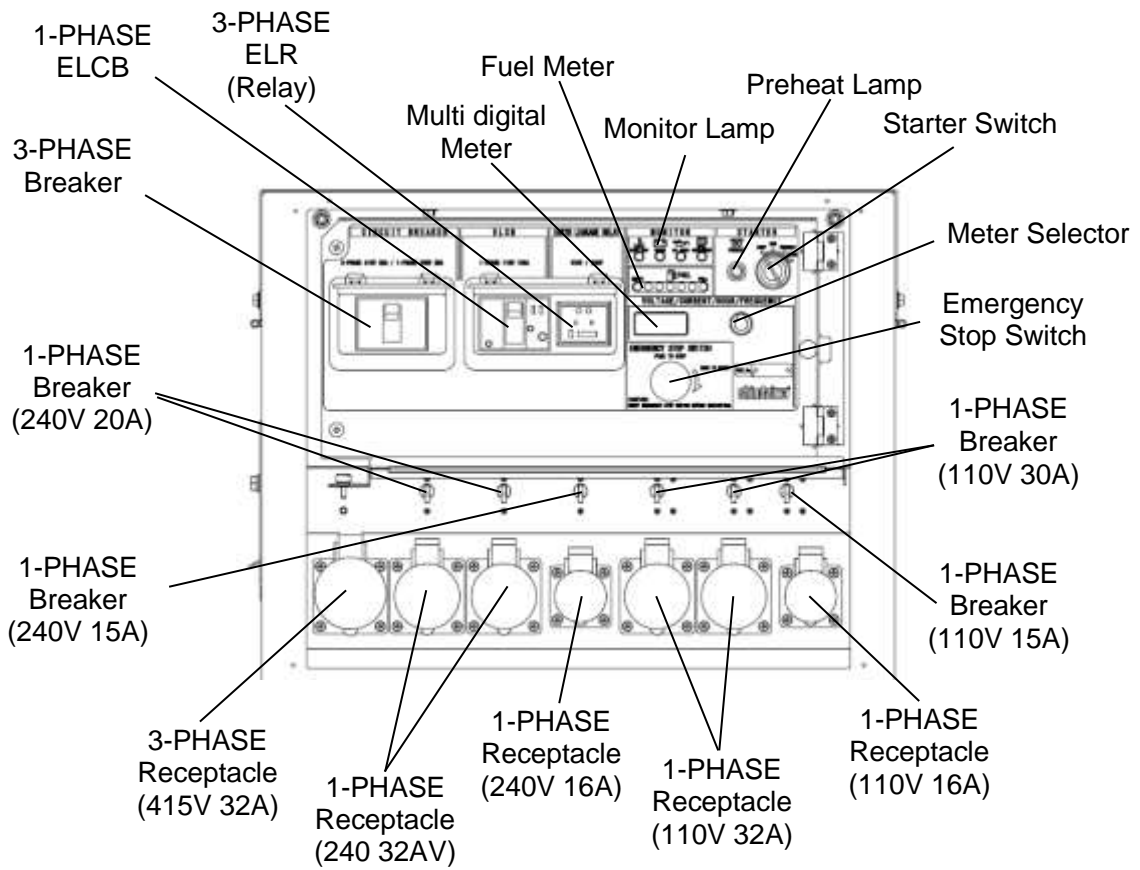

Bonnet Grounding Terminal

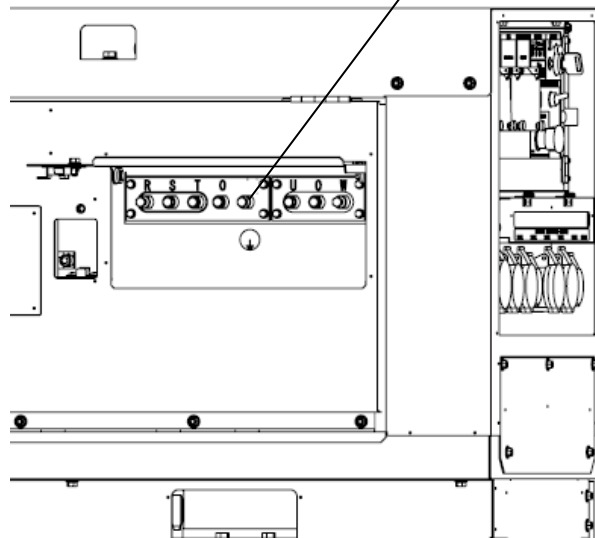

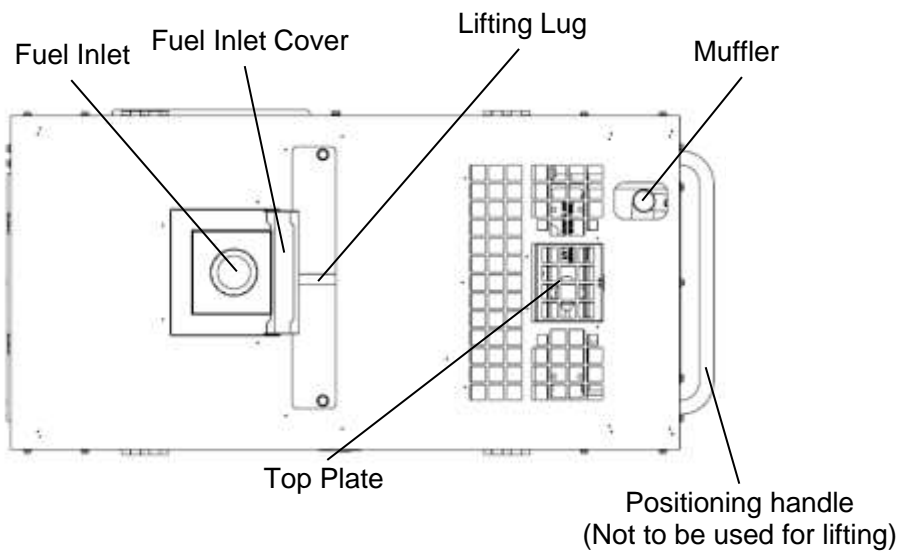
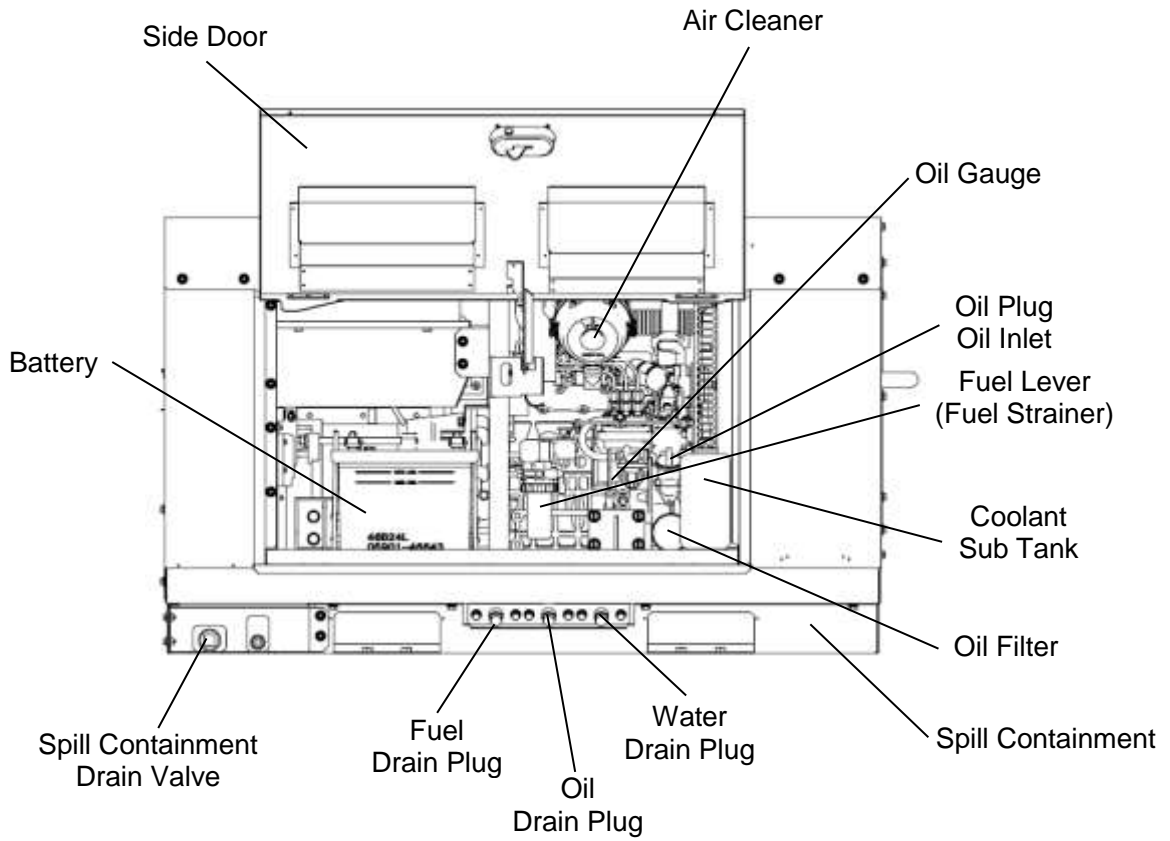

Accessories

<p>Owner's and Operators Manual</p>	<p>Starter Key 1</p>	<p>Door Key 1</p>
-------------------------------------	----------------------	-------------------

5. Equipment

5-1. Spill Containment

⚠ Warning: Fire

- Always be sure to wipe up any spilled fuel or oil.
- Spilled fuel and oil accumulates in the spill containment. Do not operate the equipment with liquid accumulated in the spill containment.
- Do not use the equipment if there is a fuel, oil or cooling water leak, and be sure to always repair the leak before using.

The equipment includes a spill containment (structure that collects leaking liquid) in order to prevent leaking liquid from getting outside of the equipment if oil, fuel or other liquid should leak.

Before starting operation, check if there is any fluid accumulated in the spill containment and drain any accumulated liquid. (Refer to section "9. (7) Draining Liquid from the Spill Containment".)

<Note>

- It is necessary to periodically drain the liquid from spill containment because any rainwater induced into the equipment accumulates in the spill containment.
- Although the fluids consist of oil, fuel and cooling water, the spill containment does not have a function that can separate rainwater leaked into the equipment from these internally leaked fluids. Properly dispose of spill from the spill containment according to the applicable federal laws and regulations.

5-2. Multi digital meter

The equipment includes a meter that provides digital display of voltage, current, operating time and frequency.

Meter is equipped with meter selector that can be switched to display voltage, current, operating time or frequency.

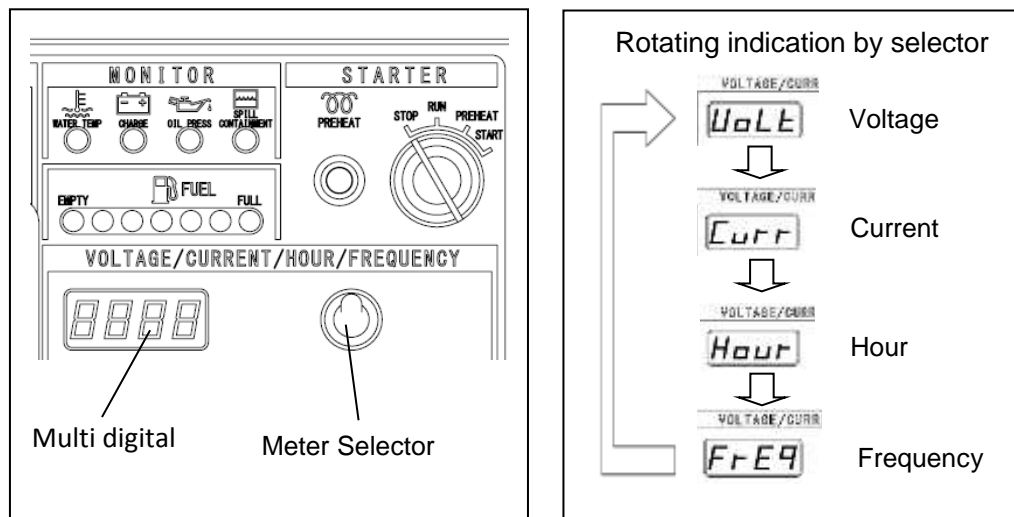

<Note>

- During operation, the 3-phase output voltage of the AC power source is constantly displayed regardless of whether the breaker for 3-phase voltage is set to "ON" or "OFF".

5-3. Error Code Display

The equipment includes an error code display [E06] function that notifies the operator of Engine over speed after the engine shuts off automatically. Consult your authorized dealer when the error code [E06] is displayed on the meter.

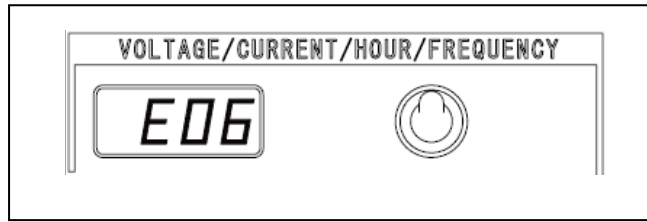

5-4. Monitor Lamp

⚠ Warning: Injuries/Electric Shock

- Do not operate the equipment with any doors or covers open. There is a danger of hair, body parts and other items being caught up in moving parts such as cooling fans and belts.

⚠ Caution: Burns

- The engine, muffler and similar parts are extremely hot during operation and immediately after stopping the equipment. Never touch hot parts.
- Never open the radiator cap during operation or immediately after stopping the equipment. Hot cooling water and steam will spurt out.
- Always be sure to stop the engine and allow it to cool before inspecting or changing the engine oil. Opening the oil gauge or oil plug during operation will result in hot oil spurting out.

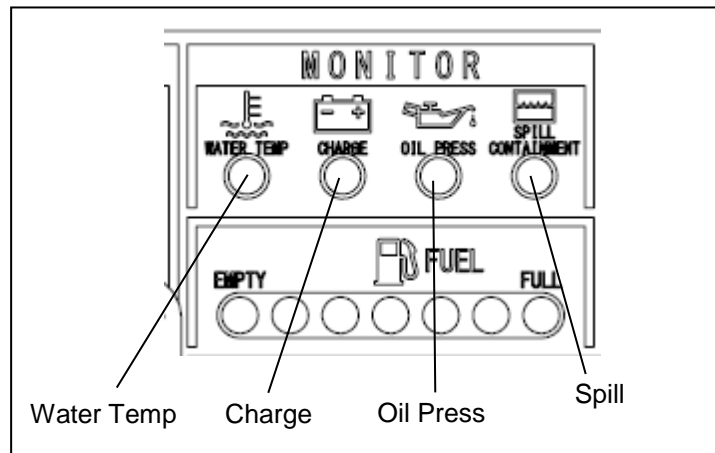

The equipment includes monitor lamps for "WATER TEMP", "CHARGE", "OIL PRESS" and "SPILL CONTAINMENT" .

If the equipment is normal, the "CHARGE" and "OIL PRESS" monitor lamps light up when the starter switch is switched from "STOP" to "RUN" , and all monitor lamps turn off when the engine is started. If any error besides that of spill containment occurs during operation, the corresponding monitor lamp lights up and the engine is automatically stopped.

If the engine is automatically stopped, return the starter switch to "STOP" and restart the engine. Watch the lit/unlit status of the monitor lamps the next time an automatic stop occurs and check the error contents.

(1) Water Temperature Monitor Lamp

The water temperature monitor lamp ("WATER TEMP") lights up and the engine is automatically stopped if the cooling water temperature becomes irregularly high during operation. If this occurs, inspect the water level of the sub tank and add cooling water if the water level is insufficient. (Refer to section "7-2. Cooling Water Inspection".)

If the cooling water in the sub tank is at the specified level, it is probable that overloading is the cause. Use within the rated output.

(2) Battery Charge Monitor Lamp

The battery charge monitor lamp ("CHARGE") lights up and the engine is automatically stopped if battery charge fails during operation. If this occurs, it is probable that there is fan belt damage or a wiring fault. Request repair at the retail outlet where the equipment was purchased.

(3) Oil Pressure Monitor Lamp

The oil pressure monitor lamp ("OIL PRESS") lights up and the engine is automatically stopped if the engine oil pressure drops during operation. If this occurs, inspect the engine oil level and fill with engine oil until it reaches the maximum level.

<Note>

- The oil pressure monitor cannot detect oil deterioration. Change the engine oil periodically. Refer to section "9. (1) Changing the Engine Oil".)
- The charge monitor cannot detect battery deterioration or insufficient battery fluid. Inspect the battery fluid level periodically. (Refer to section "7-6. Battery Inspection".)
- To inspect the fuses open the operation panel, if the engine is automatically stopped and none of the monitor lamps ("WATER TEMP", "CHARGE" and "OIL PRESS") light up. If a fuse has blown, it is probable that there is a fault in an electric part or the wiring. Request a repair at the retail outlet where the equipment was purchased.

(4) Spill Containment Monitor Lamp

The spill containment monitor lamp ("SPILL CONTAINMENT") lights up if the level of liquid in the spill containment is approximately 70% full (approx. 36 L) in order to ensure that liquid accumulated in the spill containment does not spill out of the equipment. If this occurs, drain the accumulated liquid from the equipment. (Refer to section "9. (7) Draining Liquid from the Spill Containment".)

<Note>

- The engine is not stopped if the spill containment monitor lamp lights up during operation.
- When the spill containment monitor lamp lights up during operation, stop the engine, check for fuel, oil and cooling water leakage, and repair as necessary.
- Do not use the equipment with liquid accumulated in the spill containment. Drain the spill containment before using. (Refer to section "9. (7) Draining Liquid from the Spill Containment".)

5-5. Earth Leakage Circuit Breaker and Grounding

⚠ Warning: Electric Shock

- Do not operate the equipment with wrong adjustment of Earth Leakage relay, to avoid electrical shock when the relay is not properly set.
- Always be sure to stop the engine and repair the corresponding earth leakage location when earth leakage circuit breakers operate.

⚠ Warning: Fire

- Do not ground wiring of earth leakage circuit breakers of the equipment to piping that passes through flammable material.

The equipment includes earth leakage circuit breakers (solidly grounded type) in order to prevent electric shock. Immediately isolate the electrical circuit if earth leakage occurs due to insulation failure in devices using the equipment or similar reason.

(1) Three phase 415V / Single phase 240V Earth Leakage Circuit Breaker (ELCB)

The equipment is provided with an earth leakage relay in the Circuit Breaker to detect any leakage arisen due to the troubles as insulation failure of the load while the generator is running and cutting off the circuit for protection against any accident such as electrical shock. The sensitivity current of earth leakage relay can be adjusted from 30mA to 1,000mA with duration of 0.04sec to 2.00sec by selecting slide switch located on the front panel of the leakage relay. For multiple load connection, set the leakage relay setting to be larger than each Individual leakage current of each load.

- Selection of Sensitivity Current and activation duration
Unscrew the leakage relay cover, and adjust the leakage relay to required current and duration. (Refer to the following selection table.)

Default setting is below from factory
sensitivity current : 30mA
activation duration : 0.04sec

■ Operation Check

- 1) Start the engine (Refer to 8-1).
- 2) Turn the 3-phase ELCB (lever) to [ON] position.
- 3) Push the test button on leakage relay. The device is found to be normal when the leakage indication button and the lever positions at the middle of [ON] and [OFF].
- 4) Press reset button to turn off the leakage warning indicator.
- 5) Push down the lever [OFF] on 3-phase ELCB to reset the breaker to [ON] position. Leakage relay keeps shut off the circuit once it is activated, until reset button is pressed or engine is stopped.

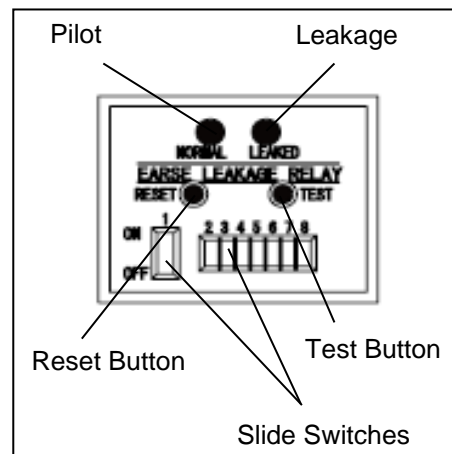

Selection of Rated Sensitivity Current

Current setting	Slide switch position				
	Switch	1	2	3	4
30mA (Operating time:0.04 sec. or less)	ON	<input type="checkbox"/>	※1		
	OFF	<input type="checkbox"/>			
100mA	ON	<input type="checkbox"/>	<input type="checkbox"/>	<input type="checkbox"/>	<input type="checkbox"/>
	OFF	<input type="checkbox"/>	<input type="checkbox"/>	<input type="checkbox"/>	<input type="checkbox"/>
300mA	ON	<input type="checkbox"/>	<input type="checkbox"/>	<input type="checkbox"/>	<input type="checkbox"/>
	OFF	<input type="checkbox"/>	<input type="checkbox"/>	<input type="checkbox"/>	<input type="checkbox"/>
500mA	ON	<input type="checkbox"/>	<input type="checkbox"/>	<input type="checkbox"/>	<input type="checkbox"/>
	OFF	<input type="checkbox"/>	<input type="checkbox"/>	<input type="checkbox"/>	<input type="checkbox"/>
1000mA	ON	<input type="checkbox"/>	<input type="checkbox"/>	<input type="checkbox"/>	<input type="checkbox"/>
	OFF	<input type="checkbox"/>	<input type="checkbox"/>	<input type="checkbox"/>	<input type="checkbox"/>

Selection of Operating Time
(not applicable to 30mA)

Time setting	Slide switch position				
	Switch	5	6	7	8
0.04sec. or less	ON	<input type="checkbox"/>	<input type="checkbox"/>	<input type="checkbox"/>	<input type="checkbox"/>
	OFF	<input type="checkbox"/>	<input type="checkbox"/>	<input type="checkbox"/>	<input type="checkbox"/>
0.3sec. (0.2-0.36 sec.)	ON	<input type="checkbox"/>	<input type="checkbox"/>	<input type="checkbox"/>	<input type="checkbox"/>
	OFF	<input type="checkbox"/>	<input type="checkbox"/>	<input type="checkbox"/>	<input type="checkbox"/>
0.5sec. (0.4-0.6 sec.)	ON	<input type="checkbox"/>	<input type="checkbox"/>	<input type="checkbox"/>	<input type="checkbox"/>
	OFF	<input type="checkbox"/>	<input type="checkbox"/>	<input type="checkbox"/>	<input type="checkbox"/>
1sec. (0.8-1.2 sec.)	ON	<input type="checkbox"/>	<input type="checkbox"/>	<input type="checkbox"/>	<input type="checkbox"/>
	OFF	<input type="checkbox"/>	<input type="checkbox"/>	<input type="checkbox"/>	<input type="checkbox"/>
2sec. (1.3-2sec.)	ON	<input type="checkbox"/>	<input type="checkbox"/>	<input type="checkbox"/>	<input type="checkbox"/>
	OFF	<input type="checkbox"/>	<input type="checkbox"/>	<input type="checkbox"/>	<input type="checkbox"/>

<Note>

※1: Whenever Switch1 is set to 「ON」 position, the setting is back to default as 30mA/0.04sec, regardless of Switch2~8 position.

(2) Single phase 110V Earth Leakage Circuit Breaker (ELCB)

Rated Sensitivity Current: 30mA (Duration 0.10sec).

■ Operation Check

- 1) Start the engine (Refer to 8-1).
- 2) Turn the 1-phase ELCB to [ON] position.
- 3) Push the test button on 1-phase ELCB. The device is found to be normal when the leakage indication button protrude and the lever positions at the middle of [ON] and [OFF].
- 4) Push down the lever [OFF] on 1-phase ELCB to reset the breaker to [ON] position.

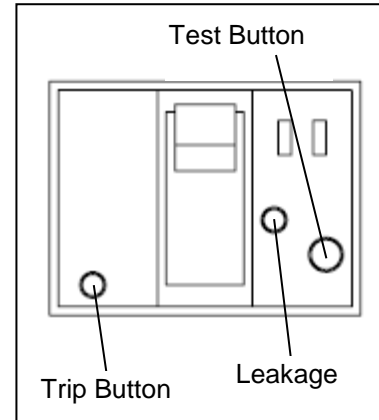

(3) Bonnet Grounding Terminal

The equipment includes a bonnet grounding terminal. In order to connect bonnet grounding wire. A neutral point of the AC power source is connected to the bonnet grounding terminal.

<Note>

- Connect using a plug with a grounding pole.
- If using a plug without a grounding pole, or output terminals, Connect load grounding earth on to the terminal directly as shown right.
- Securely ground the bonnet grounding terminal to the metal frame of the vehicle if transporting the equipment by truck or trailer.

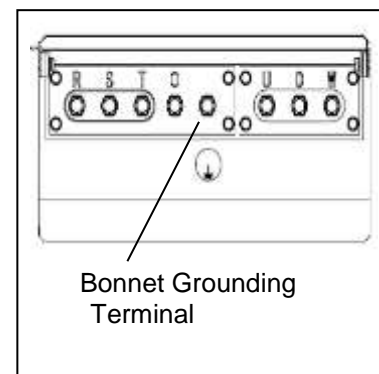

(4) If an Earth Leakage Circuit Breaker Operates

⚠ Caution: Electric Shock/Injuries

- Always be sure to turn off the power switches of all devices using the equipment when turning on the equipment breakers after an earth leakage circuit breaker operates. Leaving on the power switch of a device using the equipment when the equipment breaker is turned on could result in the sudden operation of the corresponding device.

When the ELCB relay has activated, the leakage warning lamp is turned on, or the leakage indication button protrude and the lever positions at the middle of [ON] and [OFF]. Stop the engine promptly and find the each leakage point to repair.

In case 3-phase ELCB leakage indication button does not protrude or the leakage warning lamp is not turned on, the AC output is over supply.

5-6. Emergency Stop Switch

Press the emergency stop switch to stop the engine immediately. After pressing the emergency stop switch, securely return the starter switch to the "STOP" position and turn the starter switch clockwise to reset the switch.

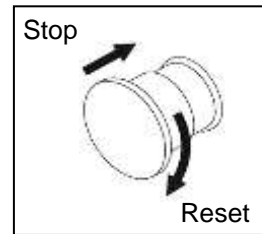

5-7. Terminal Cover Switch

An automatic engine stop feature is incorporated in the equipment, if the left side terminal cover is opened. Do not open the terminal cover while engine is operating or engine will not be restarted.

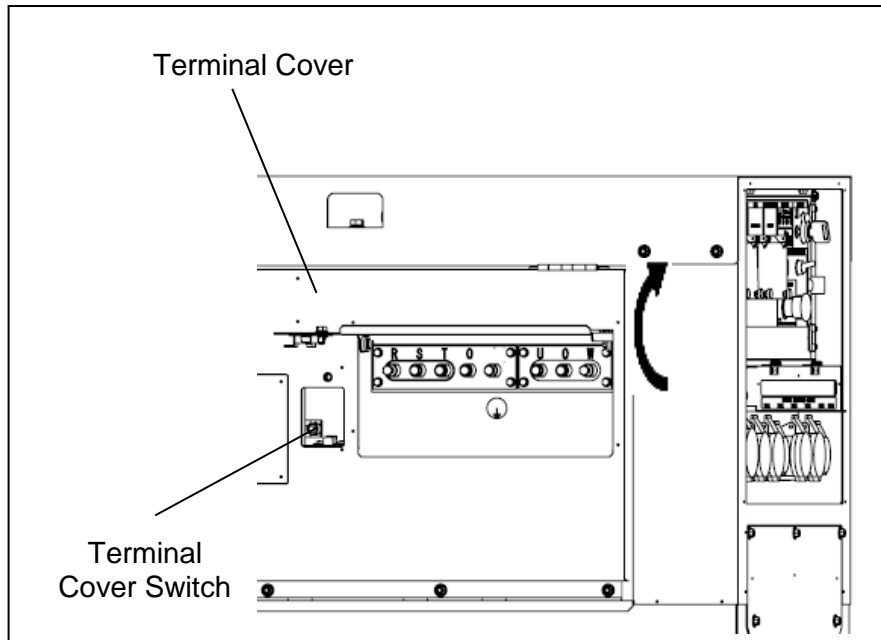

6. Load Connections

6-1. Load Cable Selection

⚠ CAUTION : PROPERTY DAMAGE

- Cable burnout can occur due to generated heat if the load current exceeds the allowable current of the cable.
- The voltage drop between cables is large if the cable is excessively long or small resulting in decreased input voltage to load using the generator, causing decreased performance, faulty operation and malfunction.

Select cable for use that has proper size and an allowable current for use, giving consideration to the distance from the generator to the load using the generator.

< NOTE >

- Select proper size of cables that ensures that the voltage drop across the cable will be within 5% of the rated voltage.
- Load Cable Selection Tables
(Ex.) If used voltage is required 415 V (±5%)

Minimum Three-phase Cabtyre (Armoured) cables

(Unit: mm²)

Length Current	50 m or less	75 m	100 m	125 m	150 m	200 m
10 A	0.75	1.25	2	2	3.5	3.5
15 A	1.25	2	3.5	3.5	3.5	5.5
20 A	2	3.5	3.5	5.5	5.5	8

(Ex.) If used voltage is required 110 V (±5%)

Minimum Single-phase Cabtyre (Armoured) cables

(Unit: mm²)

Length Current	50 m or less	75 m	100 m
10 A	3.5	5.5	8
20 A	8	14	14
30 A	14	14	22
50 A	22	22	30
70 A	22	30	50
100 A	30	50	60

6-2.Connecting Load Cables

⚠ WARNING : ELECTRIC SHOCK

- Do not touch the equipment during operation if the equipment or your body is wet.
- Be sure to stop the engine whenever touching output terminals such as when installing or removing cables.
- Do not connect cable to any part other than output terminals.
- Do not insert any metal objects, such as pins or wires, into AC output terminal or receptacles.
- Always be sure to turn off all breakers before installing or removing devices using AC output receptacles.
- Close the output terminal cover before use.

⚠ CAUTION : FIRE

- Never directly connect the generator output to commercial power supply.

< NOTE >

- When connecting a load, check that the generator output terminal or receptacles connection position are matching.
- Use proper tools when connecting a load to sufficiently tighten the connection. Failure to sufficiently tightened will result in cable burnout.

(1) Three-Phase Output Terminal

- For three-phase load:
 - Terminal voltage is 415 V.

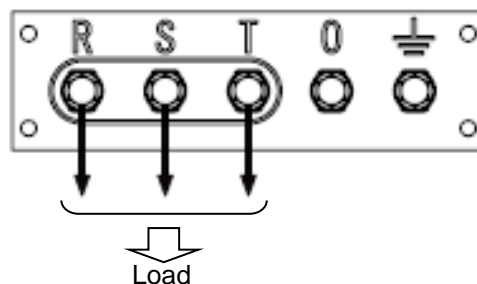

- For single-phase load:
 - Terminal voltage is 240 V.

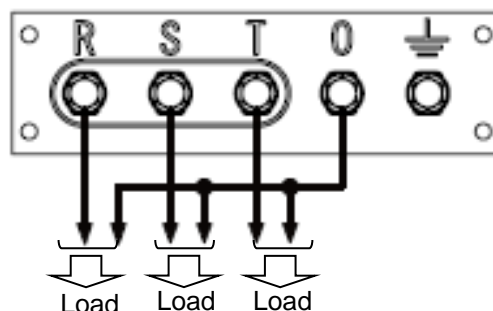

- For single-phase load:
 - Terminal voltage is 415 V.

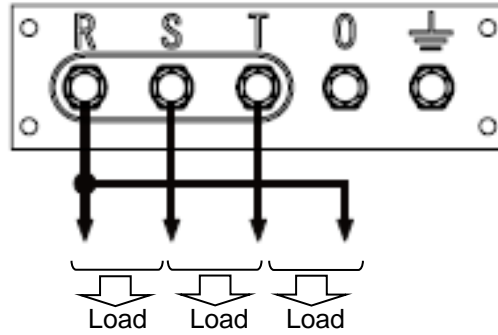

(2) Single-Phase Output Terminal and Receptacle

- For single-phase 110 V load:

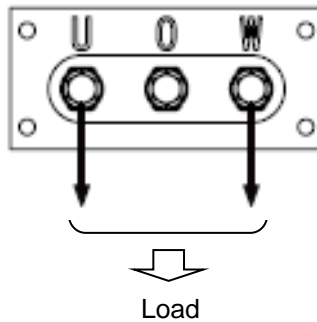

(3) Receptacle spec

3-Phase 415V
(Cover: Red)

1-Phase 240V
(Cover: Blue)

1-Phase 110V
Cover: Yellow

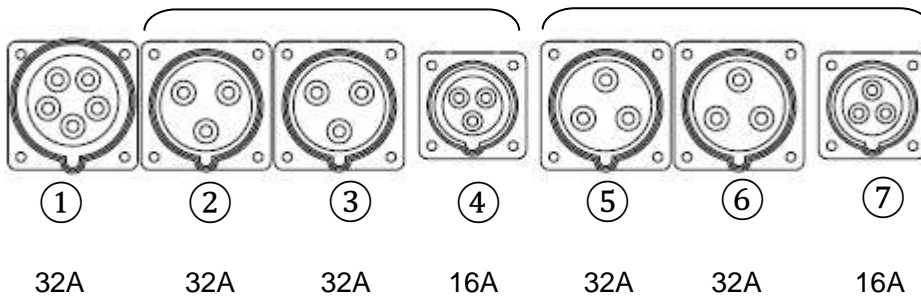

(4) Allowable maximum current for each output

■ 3-Phase 415V

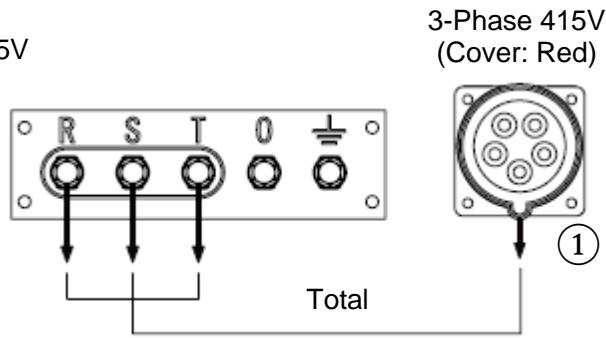

Use is possible up to the kVA as shown below.

3-Phase 415V Output Terminal	Receptacle	Total
13kVA	13kVA	13kVA

■ 1-phase 240V

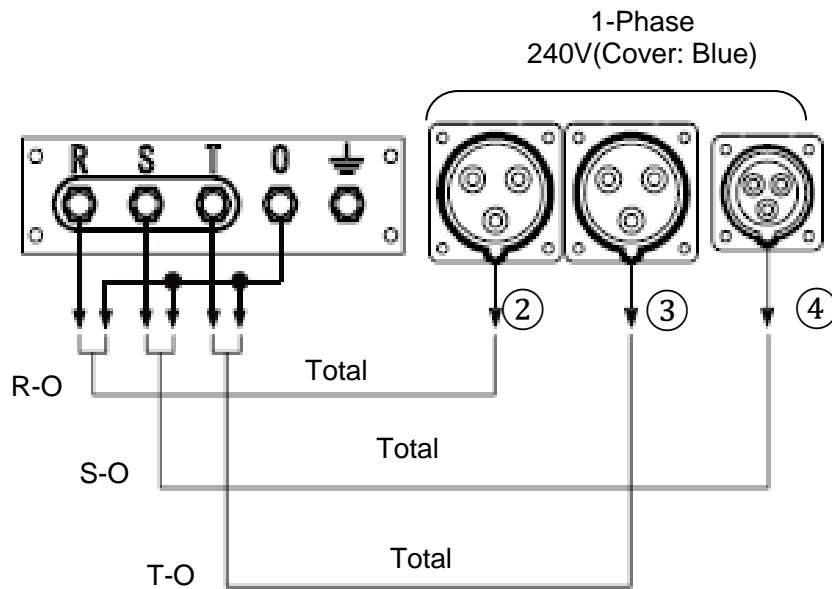

Use is possible up to the kVA as shown below.

1-phase 240V Output Terminal			Receptacle			Total	
R - O	S - O	T - O	②	③	④		
4.8kVA	-	-	4.8kVA	-	-	4.8kVA	10.4kVA
-	4.8kVA	-	-	-	3.6kVA	4.8kVA	
-	-	4.8kVA	-	4.8kVA	-	4.8kVA	

■ 1-phase 110V

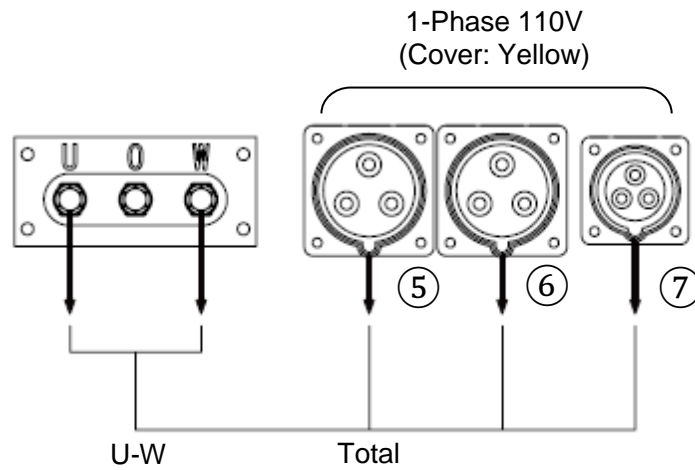

Use is possible up to the kVA as shown below.

1-phase 110V Output Terminal	Receptacle			Total
	⑤	⑥	⑦	
U - W				
10.4kVA	3.3kVA	3.3kVA	1.65kVA	10.4kVA

7. Pre-Operation Inspection

⚠ Warning: Injuries/Electric Shock

- Do not operate the equipment with any doors or covers open. There is a danger of hair, body parts and other items being caught up in moving parts such as cooling fans and belts.
- Always be sure to stop the engine and remove the starter key before performing any equipment check or maintenance.

⚠ Warning: Fire

- Always be sure to wipe up any spilled fuel or oil.
- Spilled fuel and oil accumulates in the spill containment. Do not operate the equipment with liquid accumulated in the spill containment.
- Absolutely never use the equipment if there is a fuel, oil or cooling water leak, and be sure to always repair the leak before using.
- Absolutely never inspect or perform maintenance to the equipment near fire or other open flame.

⚠ Caution: Burns

- The engine, muffler and similar parts are extremely hot during operation and immediately after stopping the equipment. Never touch hot parts.

7-1. Engine Oil Inspection

⚠ Caution: Burns

- Always be sure to stop the engine and allow it to cool before inspecting or changing the engine oil. Opening the oil gauge or oil plug during operation will result in hot oil spurting out.

Situate the equipment on a level surface and completely insert the oil gauge to inspect the oil level.

Inspect the oil level before starting operation and, if it has decreased, fill with oil until it reaches the maximum level.

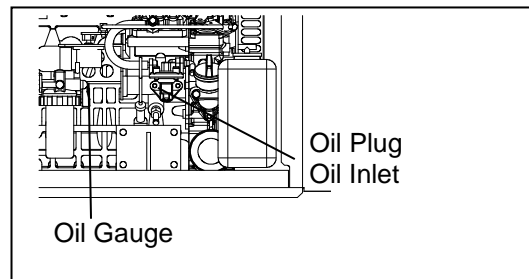

<Note>

- The oil level cannot be accurately checked if the equipment is at an angle.
- Operating the equipment when the oil has been filled above the maximum level can result in engine cylinder internal damage.

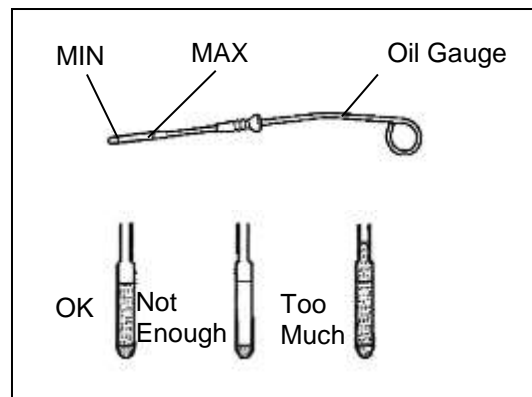

■ Engine Oil Selection

Use a diesel-type engine oil with a viscosity that is appropriate for the outdoor air temperature (refer to the table).

<Note>

- Use oil with a quality of CD class or better (API classification).

Temperature/Engine Oil Relationship

Temperature	+20°C or more	+10°C~+20°C	-10°C~+40°C
Oil Viscosity	SAE30	SAE20	SAE 10W/30

7-2. Cooling Water Inspection

⚠ Caution: Burns

- Never open the radiator cap during operation or immediately after stopping the equipment. Hot cooling water and steam will spurt out.

Check that the sub tank cooling water level is within the range of "FULL" and "LOW". If the cooling water level lower than "LOW", add water to both the sub tank and radiator.

(1) Adding Water to the Coolant Sub Tank

- 1) Remove the sub tank cap.
- 2) Pour cooling water into the sub tank until it reaches the "FULL" level.
- 3) Install the sub tank cap.

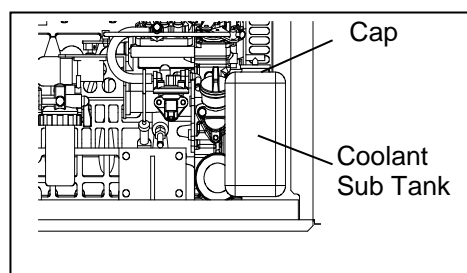

(2) Adding Water to the Radiator

- 1) Open the top plate.
- 2) Remove the radiator cap.
- 3) Pour cooling water into the radiator through the inlet port until it reaches the mouth of the port.
- 4) Tighten the radiator cap.
- 5) Close the top plate.

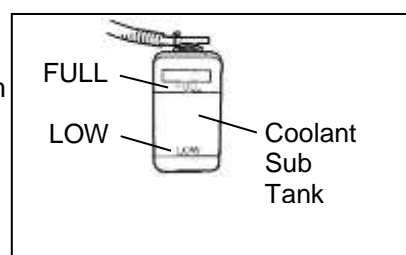

<Note>

- Use a long-life coolant (LLC) in order to prevent freezing and rust. (An LLC with a 30% mixing ratio is used when shipped from the factory.)
- Use an LLC mixing ratio in the range 30% to 45% in accordance with the outdoor air temperature.
- Change the LLC every 2,000 hours or every 2 years.

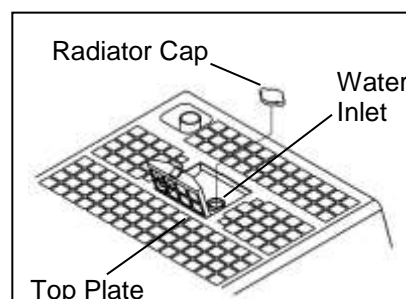

Mixing Ratio Guide

Min. Temp.	-15°C	-20°C	-30°C
Mixing Ratio	30%	35%	45%

7-3. Fuel Inspection

⚠ Warning: Fire

- Always be sure to stop the engine when inspecting fuel or refuelling, and absolutely never perform such tasks near fire or other open flame. Wait until the engine has completely cooled before inspecting fuel or refuelling.

Check that there is sufficient fuel and add fuel if insufficient.

After refuelling, securely tighten the tank cap and close the fuel inlet cover.

<Note>

- Use ASTM D975 No. 2-D diesel fuel. Do not use a substitute fuel of unknown quality as this can negatively affect the engine.
- Use a cold-weather fuel that conforms to ASTM standards if using the equipment in a cold weather region.
- Shindaiwa recommends using a fuel with a sulphur content of less than 1,000 ppm.
- Change the engine oil and oil filter after a shorter period than normal (approximately one-half the normal period) if using a high-sulphur (sulphur content of between 5,000 to 10,000 ppm) fuel.
- Do not use a fuel with a sulphur content of 10,000 ppm or more. Ultra-low sulphur fuel must be used if using the equipment in a region subject to EPA exhaust gas regulations. Use No. 2-D S15 in place of No. 2-D in such areas. Use No. 1-D S15 in place of No. 1-D in regions where the temperature is -10°C or less.
- Always be sure to use the fuel strainer attached to the fuel inlet.
- Add fuel until the tank is slightly less than full.
- Do not open the fuel inlet cover except when refuelling. Leaving the fuel inlet cover open can result in rainwater flowing into the equipment and cause the fluids in the spill containment (oil and similar fluids) to spill out of the equipment.

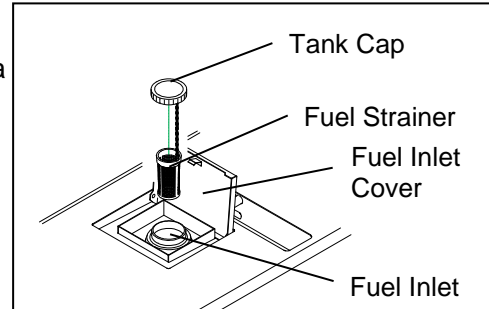

7-4. Spill Containment Inspection

⚠ Warning: Fire

- Spilled fuel and oil accumulates in the spill containment. Do not operate the equipment with liquid accumulated in the spill containment.

Open the side door, check inside of the spill containment, and drain any liquid that has accumulated. (Refer to section "9. (7) Draining Liquid from the Spill Containment".)

<Note>

- It is necessary to periodically drain the liquid from within the equipment because any rainwater that leaks into the equipment also accumulates in the spill containment.
- Although the fluids that can leak internally consist of oil, fuel and cooling water, the spill containment does not have a function that can separate rainwater that has leaked into the equipment from these internally leaked fluids. Properly dispose of liquid drained from the spill containment in a manner according to the applicable laws and regulations.

7-5. Inspection for Fuel/Oil/Cooling Water Leakage

⚠ Warning: Fire

- Absolutely never use the equipment if there is a fuel, oil or cooling water leak, and be sure to always repair the leak before using.

Open the side door and check for fuel leakage from fuel line joints and similar components, and check for oil and cooling water leakage. Open the fuel tap to perform inspection and close it after inspection has been completed.

7-6. Battery Inspection

⚠ Warning: Injuries to Eyes and Skin

- Use protective gear, such as rubber gloves, when inspecting or replacing the battery due to the dilute sulphuric acid in the battery fluid. Be sure that fluid does not get into eyes, or on skin or clothing.
- If battery fluid gets into the eyes, or on the skin or clothing, immediately wash with a large amount of water, and always be especially sure to seek medical attention if it gets into the eyes.

⚠ Warning: Explosion

- Do not operate the equipment or recharge the battery when the battery fluid level is below the lower level.
- Do not generate any sparks near the battery and do not allow any fire or other open flame near the equipment because the battery generates ignitable gas.

- 1) Inspect the battery fluid level. If it is near the lower level, add distilled water until it reaches the upper level.
- 2) Inspect for loose terminals and retighten if loose.

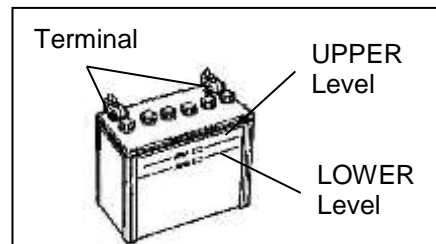

<Note>

- It is necessary to recharge the battery when the specific gravity of the battery fluid is 1.23 or less. Contact the retail outlet where the equipment was purchased if this occurs.

■ Battery Replacement Procedures

- 1) Remove the "-" (negative) cable.
(Always be sure to first remove the "-" (negative side).)
- 2) Remove the battery hold-down clamp.
- 3) Remove the "+" (positive) cable.
- 4) Remove the battery.

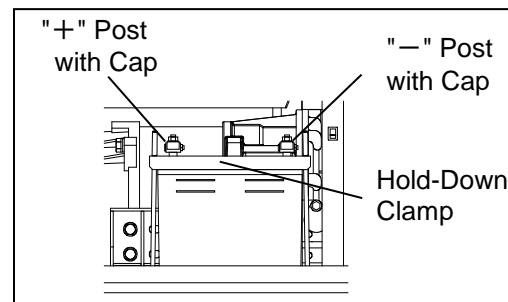

- * Install the battery by performing the above procedures in reverse order. (Always be sure to first attach the "+" (positive) side.)

<Note>

- Use the specified battery. <46B24L> (Japanese Industrial Standard)

8. Operating Procedures

⚠ Warning: Suffocation from Exhaust Fumes

- Do not operate the equipment in a poorly-ventilated area such as indoors or within a tunnel because the engine exhaust fume includes components that are harmful to humans.

⚠ Warning: Fire

- Keep any ignitable items (such as fuel, gas and paint) or inflammable items away from the equipment because the muffler, exhaust fume and other parts attain high temperatures.
- Provide at least 1 meter (3 feet) of distance between the equipment and walls and other obstacles, and operate the equipment on a flat surface.

⚠ Warning: Electric Shock

- Always be sure to turn off all breakers before installing or removing devices using output receptacles or terminal.
- Always be sure to repair the corresponding earth leakage location when earth leakage circuit breakers operate.

⚠ Caution: Suffocation from Exhaust Fumes

- Do not direct the engine exhaust towards passersby, private homes or similar persons/locations because the engine exhaust fume includes components that are harmful to humans.

⚠ Caution: Burns

- The engine, muffler and similar parts are extremely hot during operation and immediately after stopping the equipment. Never touch hot parts.

⚠ Caution: Injuries

- Use this equipment with it situated on a stable level surface so that it is prevented from moving.
- Do not move the equipment during operation.
- Always be sure to turn off the switches of all devices using the equipment and turn off the equipment breakers before starting the engine.
- Always be sure to turn off the power switches of all devices using the equipment when turning on the equipment breakers. Leaving on the power switch of a device using the equipment when the equipment breakers are turned on could result in the sudden operation of the corresponding device.
- Do not leave on the power switch of a device using the equipment and do not connect a device to an output receptacle or terminal.

⚠ Caution: Physical and Secondary Damage

- If using the equipment as a power source for medical equipment, you must check with the medical equipment manufacturer, doctor and hospital before using the equipment.

<Note>

- Check that the surrounding area is safe before starting the engine.
- When there are multiple workers who are working together, they must mutually signal each other before starting the engine.
- Do not use in an area with high temperature or humidity, or an area with a large amount of dust.
- Do not open any doors during operation. Operating with a door open can negatively affect cooling effect, resulting in an equipment malfunction.
- Use ear protection if the level of noise is high. Failure to do so could result in hearing damage.

8-1. Initial start-up / Pre-check

- 1) Turn all connected equipment's switch to "OFF"
- 2) Turn all breakers (3-P, 1-P and circuit protector) to "OFF".
- 3) Turn the fuel lever (on the fuel strainer) to "OPEN".
- 4) Check the emergency stop switch is released and terminal covers are closed.
- 5) If the temperature is 5°C or less, turn the starter switch to the "PREHEAT" position and wait until the preheat lamp turns off. (Approx. 5 seconds)
- 6) Turn the starter switch to the "START" position to start the starter motor, which then starts the engine.
- 7) After the engine starts, remove your hand from the starter switch.
- 8) Allow the engine to warm up for approximately 5 minutes.
- 9) Turn the breakers to "ON" to start power transmission.

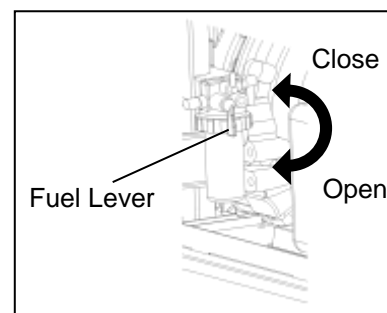
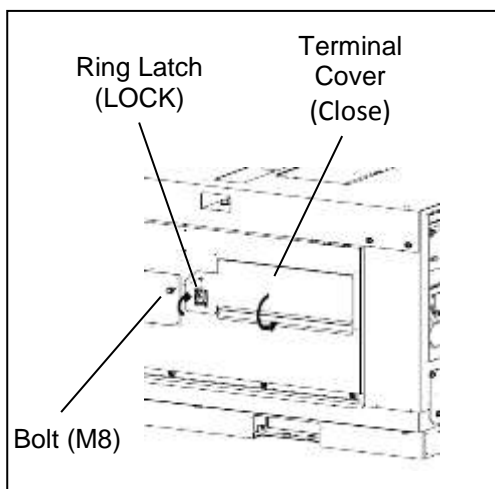
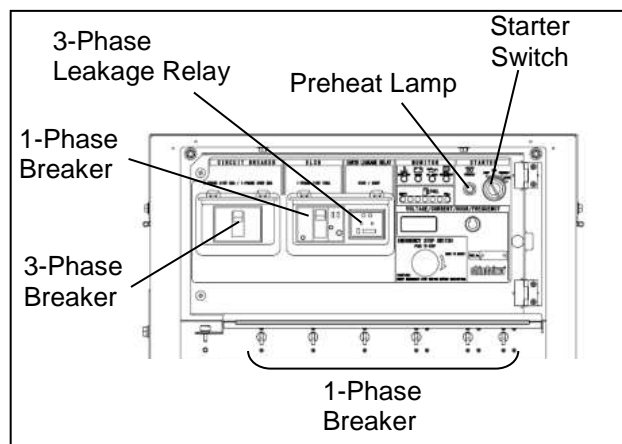

<Note>

- Do not crank the starter motor for 15 seconds or more continuously.
- If repeating starter switch operation, wait 30 seconds or more between operations.
- After the engine starts, do not turn the starter switch to "START" during operation.
- During operation, the 3-phase output voltage of the power source is constantly displayed by the meter voltage display regardless of whether the breaker is set to "ON" or "OFF".

■ Restarting after Stopping due to Running Out of Fuel

The equipment includes an automatic air-bleeding device. You can easily restart the engine according to the following procedures even if the engine stops due to running out of fuel.

- 1) Turn all breakers (3-P, 1-P and circuit protector) to "OFF".
- 2) Turn the starter switch to the "STOP" position.
- 3) Add fuel to the fuel tank.
- 4) Turn the starter switch to the "START" position and crank the starter motor for approximately 10 seconds.
- 5) After the engine starts, remove your hand from the starter switch.
- 6) Wait for air to be completely bled from the fuel pipes and engine speed to stabilize (approx. 1-minute). (Engine speed is not stable until all air is bled from the fuel pipes.)

<Note>

- Do not apply any loads until all the air has been bled from the fuel pipes (until speed is stable). Doing so can cause a malfunction.

■ Recovery from Overcurrent Breaker Operation

⚠ Caution: Injuries

- Always be sure to turn off the power switches of all devices using the equipment when turning on the equipment breakers. Leaving on the power switch of a device using the equipment when the equipment breakers are turned on could result in the sudden operation of the corresponding device.

Breakers operate when there is excessive current to isolate the corresponding circuit. Inspect the breakers if a device being used stops during equipment operation.

Follow the following procedures to recover operation when breakers operate due to overcurrent.

- 1) Turn off all switches of devices using the equipment as an AC power source.
- 2) Push up the breaker lever that have operated to the "ON" position.

8-2. Stopping the Engine

- 1) Turn all breakers (main, 3-P and 1-P and circuit protector) to "OFF".
- 2) Allow the engine to cool down for approximately 5 minutes.
- 3) Set the starter switch to "STOP".
- 4) After the engine stops, turn the fuel lever to "CLOSE".

<Note>

- Do not stop the engine while using as an AC power source. Doing so can cause a malfunction.
- If the engine does not stop when the starter switch is set to "STOP", turn the fuel lever to "CLOSE". The engine will stop a few minutes afterwards. If the engine does not stop by starter switch operation, stop using the equipment and request repair at the retail outlet where the equipment was purchased.

8-3. Emergency Stop

The equipment includes an emergency stop device.

Press the emergency stop switch if you want to immediately stop the engine when an emergency occurs in the work area, the equipment suffers an operating fault, and similar circumstances.

<Note>

- After stopping the engine using the emergency stop device, turn the starter switch to "STOP".
- Do not strike the emergency stop switch with a hammer or similar tool.
- Only use the emergency stop switch for emergency stop purposes.
- If the engine does not stop when the emergency stop switch is pressed, turn the fuel lever to "CLOSE". The engine will stop a few minutes afterwards.

8-3.Protective Functions

WARNING: Injuries

- Do not open the check door during operation. Be careful of pinching or catching of moving parts such as the cooling fan and fan belt.
- Always be sure to stop the engine and remove the engine key when performing inspection or maintenance.

CAUTION: Burns

- Do not touch the engine and surrounding components immediately after stopping the engine as they are still hot.
- Hot steam gushes out from the coolant subtank if the generator overheats. Do not touch the coolant subtank.

This generator is equipped with functions to automatically stop operation when there is a fault/malfunction during operation, and one to warn the operator of the fault location by use of indicator lamps. Check the fault location when the engine is automatically stopped or an indicator lamp lights up to stop the engine.

Protection Feature List

No	Action		Breaker Trip	Engine Automatic Shutdown	Warning	Cause
	Abnormality					
1	Monitor Lamp	High Water Temperature	–	○	○※1	Activates due to high water temperature in the engine Default 115°C
2		Low Oil Pressure	–	○	○※1	Activate due to low oil pressure in the engine Default 98 kPa
3		Battery Charge Insufficient	–	○	○※1	Activates by insufficient charging system.
4		Spill Containment Fluid Level	–	–	○※1	Spill containment accumulated fluid has exceeded the specified level making it necessary to flush the fluid.
5	Engine Overspeed		–	○	○※2	Engine speed is exceeded 4140 min-1 or more
6	Short Circuit		○	–	○※3	Activates in short circuit
7	Overload		○	–	–	Activates in overload
8	Terminal cover open		–	○	–	Activates when terminal cover is opened.

○ Indicates the automatic activation.

※1: Warning lamp is turned on (Refer to 5-4)

※2: Indicates 「E06」 on the multi meter.(Refer to 5-3)

※3: Leakage warning lamp is turned on, or the leakage indication button protrude.(Refer to 5-5)

9. Inspection/Maintenance

Warning: Electric Shock/Injuries

- Do not touch the equipment during operation if the equipment or your body is wet.
- Always be sure to stop the engine and remove the starter key before performing any equipment check or maintenance.
- Do not operate the equipment with any doors or covers open. There is a danger of hair, body parts and other items being caught up in moving parts such as cooling fans and belts.
- Do not modify the equipment and do not operate with parts removed.

Warning: Fire

- Always be sure to stop the engine when inspecting fuel or refuelling, and absolutely never perform such tasks near fire or other open flame. Wait until the engine has completely cooled before inspecting fuel or refuelling.
- Always be sure to wipe up any spilled fuel or oil.
- Spilled fuel and oil accumulates in the spill containment. Do not operate the equipment with liquid accumulated in the spill containment.
- Absolutely never use the equipment if there is a fuel, oil or cooling water leak, and be sure to always repair the leak before using.
- Absolutely never inspect or perform maintenance to the equipment near fire or other open flame.

Warning: Injuries to Eyes and Skin

- Use protective gear, such as rubber gloves, when inspecting or replacing the battery due to the dilute sulphuric acid in the battery fluid. Be sure that fluid does not get into eyes, or on skin or clothing.
- If battery fluid gets into the eyes, or on the skin or clothing, immediately wash with a large amount of water, and always be especially sure to seek medical attention if it gets into the eyes.

Warning: Explosion

- Do not operate the equipment or recharge the battery when the battery fluid level is below the lower level.
- Do not generate any sparks near the battery and do not allow any fire or other open flame near the equipment because the battery generates ignitable gas.

Caution: Burns

- The engine, muffler and similar parts are extremely hot during operation and immediately after stopping the equipment. Never touch hot parts.
- Never open the radiator cap during operation or immediately after stopping the equipment. Hot cooling water and steam will spurt out.
- Always be sure to stop the engine and allow it to cool before inspecting or changing the engine oil. Opening the oil gauge or oil plug during operation will result in hot oil spurting out.

<Note>

- Procedures except for pre-operation inspection must be performed by specialized technicians.
- Items indicated by ●: Contact the retail outlet where the equipment was purchased.
- Always be sure to use genuine parts when replacing parts.
- When removing waste liquid from the equipment, place some container to collect the liquid and prevent it from spilling on the ground. Dispose of such oil, fuel, cooling water (LLC), filters, batteries and other harmful substances as industrial waste in accordance with applicable laws and regulations. Consult with the retail outlet where the equipment was purchased if you have any inquiries regarding proper disposal.
- When performing maintenance with doors or covers open, be sure that no other persons can accidentally come close to the equipment. Close all doors and covers if momentarily leaving the equipment unattended.

Perform periodic inspection and maintenance as indicated by the table below in order to ensure that this equipment can be operated in optimal condition.

Use the hour meter as a general indicator for the operating time.

	Inspection Item	Daily	Inspection Period					
			50 hours	Every 100 hours	Every 200 hours	Every 400 hours	Every 1,000 hours	Every 2,000 hours
1	Inspect/Add Fuel	○						
2	Inspect/Add Engine Oil	○						
3	Change Engine Oil		1st time ○	2nd time and after ○				
4	Change Oil Filter		1st time ○		2nd time and after ○			
5	Inspect/Add Cooling Water	○						
6	Change Cooling Water							○ Or 2years
7	Clean Fuel Strainer		1st time ○	2nd time and after ○				
8	Replace Fuel Element					○		
9	Drain Water from/Clean Fuel Tank				○			
10	Inspect for Fuel/Oil/Cooling Water Leakage	○						
11	Inspect/Add Battery Fluid	○						
12	Clean Air Element		1st time ○	2nd time and after ○				
13	Replace Air Element					○		
14	Drain Liquid from Spill Containment	○						

15	Adjust V-belt Tension		1st time •	2nd time and after •				
16	Replace V-belt					• Or 2years		
17	Clean Radiator Fin (External)					•		
18	Clean Radiator (Internal)					•		
19	Replace Fuel/Cooling Water/Oil Hoses and Anti-Vibration Rubber							• Or 2years
Inspection Item		Pre-Operation Inspection	Inspection Period					Every 2,000 hours
			50 hours	Every 100 hours	Every 200 hours	Every 400 hours	Every 1,000 hours	
20	Adjust/Lap Clearance of Air Intake/Release Valves						• Adjustment	• Lapping
21	Inspect/Adjust Clearance of Fuel Injection Valves					•		
22	Inspect/Adjust Fuel Injection Pump							•
23	Clean/Inspect Spill Containment					• Or 1years		

(1) Changing the Engine Oil

1st time	50 hours
2nd time and after	Every 100 hours

- 1) Remove the oil plug.
- 2) Remove the oil drain plug and drain the engine oil.
- 3) Tighten the oil drain plug.
- 4) Add oil through the oil inlet, while checking the oil level using the oil gauge, until it reaches the maximum level. (Fill with approx. 3.6 L.)
- 5) Tighten the oil plug.

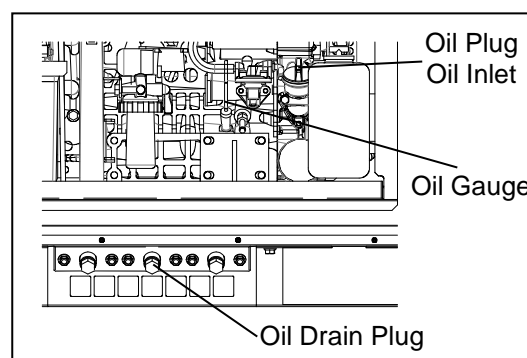

<Note>

- Refer to section "7-1. Engine Oil Inspection" for the types of engine oil.
- Replace the packing of the oil drain plug with a new part each time the oil is changed.
- Packing part no.: 6C090-58961 (Kubota part no.)
- After tightening the oil drain plug, operate the engine for a short period and check that there is no oil leakage. Stop the engine when completed.

(2) Changing the Oil Filter

1st time	50 hours
2nd time and after	Every 200 hours

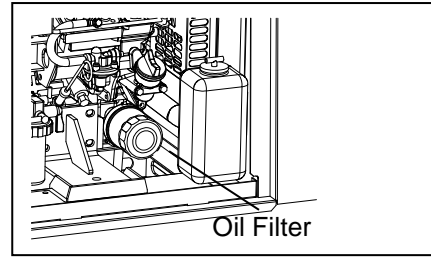

- 1) Drain the engine oil according to the procedures of " (1) Changing the Engine Oil".
- 2) Remove the oil filter using a filter wrench.
- 3) Apply a thin layer of oil to the gasket of a new oil filter.
- 4) Screw in the oil filter by hand and securely tighten by hand (do not use a filter wrench) after the gasket contacts the seal surface.
- 5) Add engine oil.

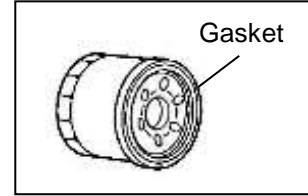

<Note>

- Contact the retail outlet where the equipment was purchased if you do not have a filter wrench.
- Oil filter part no.: 15853-32436 (Kubota part no.)
After adding engine oil, operate the engine for a short period and check that there is no oil leakage. Stop the engine when completed.

(3) Cleaning/Replacing the Air Element

Cleaning	1st time: 50 hours 2nd time and after: Every 100 hours
Replacement	Every 400 hours

- 1) Release the air cleaner clips and remove the cleaner cap.
- 2) Clean or replace the air element.
<If dry dust is adhering>
Spray compressed air from within the element.
<If carbon or oily substance is adhering>
Replace with a new part.
- 3) Install in the reverse order of removal.

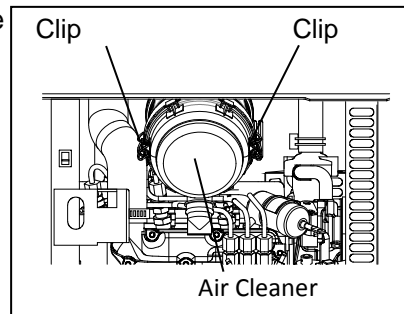

<Note>

- Clean sooner than scheduled if using the equipment in a dusty location.
- Element part no.: 1G319-11211(Kubota part no.)

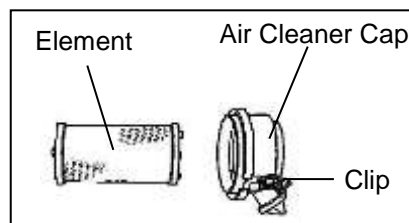

(4) Cleaning/Replacing the Fuel Strainer

Cleaning	1st time: 50 hours 2nd time and after: Every 100 hours
Replacement	Every 400 hours

- 1) Turn the fuel lever to "CLOSE".
- 2) Turn the retainer ring to the left and remove the cup and element.
- 3) Remove any water or foreign material from the cup and clean the element using compressed air. (Or replace the element.)
- 4) Install in the reverse order of removal.

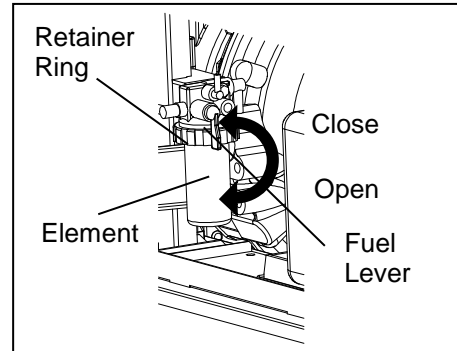

<Note>

- Check that no foreign material is adhering to the packing then install the cup.
- After installation, turn the fuel lever to "OPEN" and check that there is no fuel leakage. After checking, turn the fuel lever to "CLOSE".
- Element part no: 16271-43561 (Kubota part no.)

(5) Draining Water from the Fuel Tank

Draining Water	Every 200 hours
----------------	-----------------

- 1) Remove the fuel drain plug.
- 2) Drain the water and tighten the fuel drain plug.

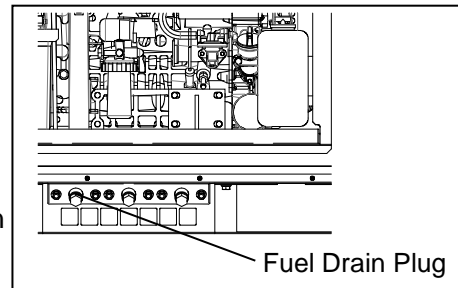

<Note>

- Replace the packing with a new part each time you drain the water.
- Packing part no.: 6C090-58961 (Kubota part no.)
- Always be sure to check that there is no fuel leakage after tightening the fuel drain plug.

(6) Changing the Cooling Water

Change	Every 2,000 hours or 2 years
--------	------------------------------

Cooling Water Total Capacity: Approximately 4 L
(Including the sub tank capacity of approx. 0.6 L

- 1) Open the top plate.
- 2) Remove the radiator cap.
- 3) Remove the water drain plug.
- 4) Drain the cooling water and tighten the water drain plug.
- 5) Change the cooling water in the sub tank.
- 6) Pour cooling water into the water inlet until it reaches the mouth of the port.
- 7) Tighten the radiator cap.
- 8) Close the top plate

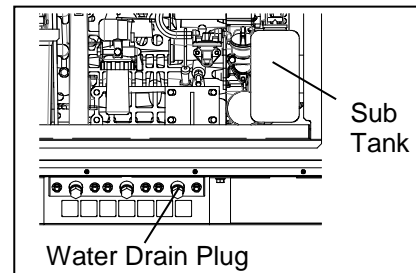
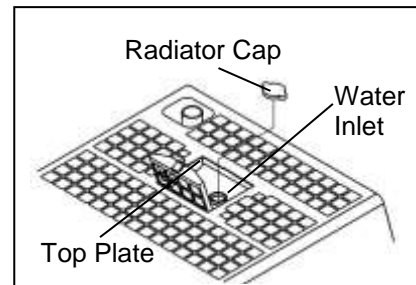

<Note>

- Replace the packing with a new part each time you change the cooling water.
- Packing part no.: 6C090-58961 (Kubota part no.)
- Operate the engine for a short period and check that there is no cooling water leakage. Stop the engine when completed.

(7) Drain the Spill Containment

Drain	Pre-operation
-------	---------------

- 1) Set a large pans or bucket under the drain port of the spill containment to catch the liquid.
- 2) Remove the guard by loosening bolts.
- 3) Remove the plug (R 1") of the spill containment drain valve and turn the plug counter clock wise.
- 4) Tighten the (R 1") plug with thread seal tape by 19.6N-m.(by adjustable wrench)
- 5) Reinstall the guard.

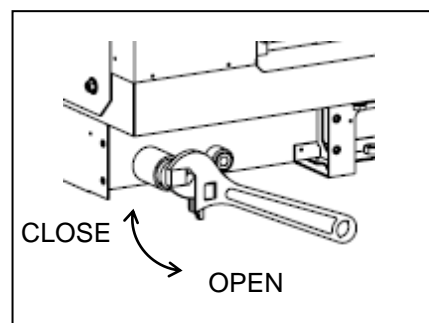
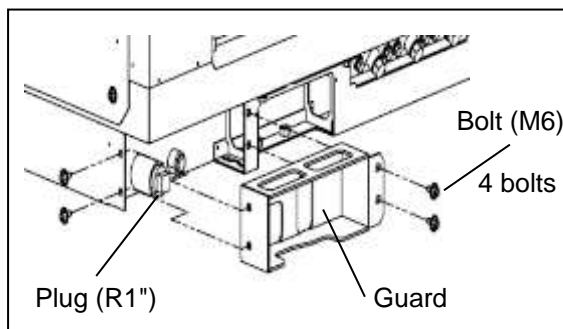

<Note>

- It is possible that there is a fuel or oil leak if the drained fluid contains oily components. If this occurs, check for leakage locations. Although the fluids that can leak internally consist of oil, fuel, cooling water and battery fluid, the spill containment does not have a function that can separate rainwater that has leaked into the equipment from these internally leaked fluids. Properly dispose of liquid drained from the spill containment in a manner according to the applicable laws and regulations.

(8) Cleaning/Inspecting the Spill Containment

Clean / Inspect	Every 400 hours or 1 year
-----------------	---------------------------

⚠ Caution: Injuries

- Always be sure to use the lifting lug when lifting the equipment, and lift slowly and directly straight above.
- Wear a helmet, safety shoes, gloves and similar protective gear when performing lifting work. Do not stand or get under the equipment while it is suspended.
- For cleaning/inspecting the spill containment, set this equipment with it situated on a stable level surface so that it is prevented from moving.

- 1) Drain the spill from the containment.
- 2) Remove the seven installation bolts (M8) of the spill containment.
- 3) Lift up the equipment body to separate the spill containment and set the equipment on a level surface.
- 4) Clean the inside of the spill containment using a high-pressure washer or similar equipment.
- 5) Drain the cleaning liquid from the spill containment.
- 6) Remove any rust that has formed in the spill containment and paint it again.
- 7) Pour water into the spill containment and check that there is no leakage. (After checking, drain the water you have used.)
- 8) Install the spill containment to the equipment in the reverse order of removal.

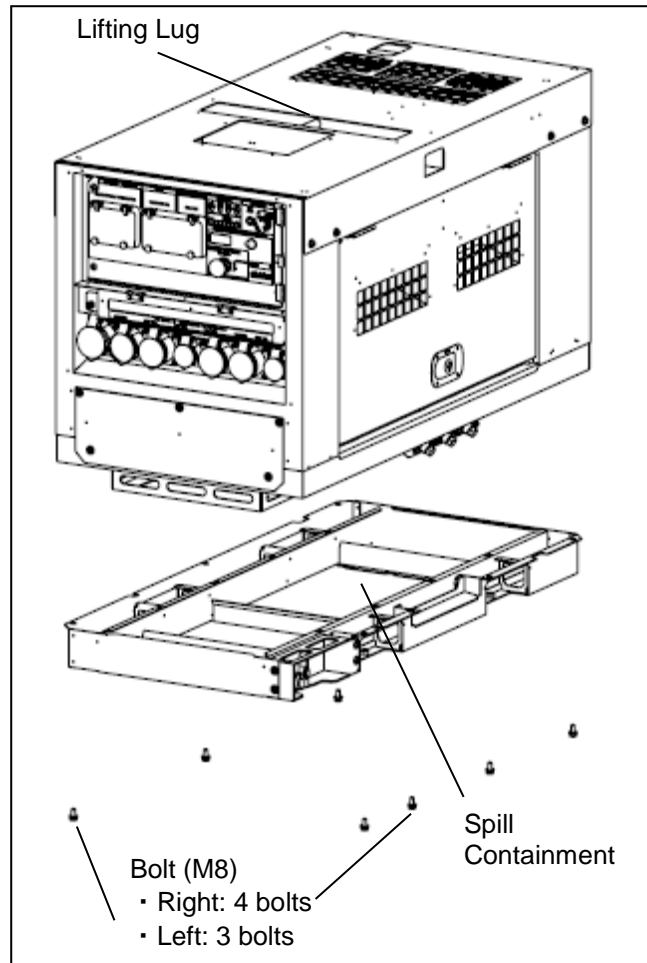

<Note>

- Do not operate the equipment with the spill containment separated.
- If liquid drained from the spill containment during cleaning contains oily components, dispose of it in a manner according to the applicable laws and regulations. If the spill containment has a leak, request repair at the retail outlet where the equipment was purchased.

10. Long-Term Storage

⚠ Warning: Electric Shock/Injuries

- Always be sure to stop the engine and remove the starter key before performing any equipment check or maintenance.
- Do not operate the equipment with any doors or covers open. There is a danger of hair, body parts and other items being caught up in moving parts such as cooling fans and belts.
- Do not modify the equipment and do not operate with parts removed.

⚠ Warning: Fire

- Always be sure to stop the engine when inspecting fuel or refuelling, and absolutely never perform such tasks near fire or other open flame. Wait until the engine has completely cooled before inspecting fuel or refuelling.
- Always be sure to wipe up any spilled fuel or oil.
- Spilled fuel and oil accumulates in the spill containment. Do not operate the equipment with liquid accumulated in the spill containment.

⚠ Caution: Burns

- The engine, muffler and similar parts are extremely hot during operation and immediately after stopping the equipment. Never touch hot parts.
- Always be sure to stop the engine and allow it to cool before inspecting or changing the engine oil. Opening the oil gauge or oil plug during operation will result in hot oil spurting out.

Perform the following maintenance procedures if not using the equipment for two months or more.

- 1) Remove the battery. (Refer to section "7-6. Battery Inspection".)
- 2) Change the engine oil. (Refer to section "9. (1) Changing the Engine Oil".)
- 3) Drain the fuel from the fuel tank and strainer.
(Refer to section "9. (4) Cleaning/Replacing the Fuel Strainer".)
- 4) Clean and inspect the spill containment.
(Refer to section "9. (8) Cleaning/Inspecting the Spill Containment".)
- 5) Remove the starter key and store in a secure location.
- 6) Clean all parts and store the equipment in an area with low humidity and little dust with a cover or similar protection covering it.

<Note>

Recharge a removed battery approximately once every month.

11. Troubleshooting

⚠ Warning: Electric Shock/Injuries

- Do not touch the equipment during operation if the equipment or your body is wet.
- Always be sure to stop the engine and remove the starter key before performing any equipment check or maintenance.
- Do not operate the equipment with any doors or covers open. There is a danger of hair, body parts and other items being caught up in moving parts such as cooling fans and belts.

⚠ Warning: Fire

- Always be sure to stop the engine when inspecting fuel or refuelling, and absolutely never perform such tasks near fire or other open flame. Wait until the engine has completely cooled before inspecting fuel or refuelling.
- Always be sure to wipe up any spilled fuel or oil.
- Spilled fuel and oil accumulates in the spill containment. Do not operate the equipment with liquid accumulated in the spill containment.
- Absolutely never use the equipment if there is a fuel, oil or cooling water leak, and be sure to always repair the leak before using.
- Absolutely never inspect or perform maintenance to the equipment near fire or other open flame.

⚠ Warning: Injuries to Eyes and Skin

- Use protective gear, such as rubber gloves, when inspecting or replacing the battery due to the dilute sulphuric acid in the battery fluid. Be sure that fluid does not get into eyes, or on skin or clothing.
- If battery fluid gets into the eyes, or on the skin or clothing, immediately wash with a large amount of water, and always be especially sure to seek medical attention if it gets into the eyes.

⚠ Warning: Explosion

- Do not operate the equipment or recharge the battery when the battery fluid level is below the lower level.
- Do not generate any sparks near the battery and do not allow any fire or other open flame near the equipment because the battery generates ignitable gas.

⚠ Caution: Burns

- The engine, muffler and similar parts are extremely hot during operation and immediately after stopping the equipment. Never touch hot parts.
- Never open the radiator cap during operation or immediately after stopping the equipment. Hot cooling water and steam will spurt out.
- Always be sure to stop the engine and allow it to cool before inspecting or changing the engine oil. Opening the oil gauge or oil plug during operation will result in hot oil spurting out.

Refer to the table below to perform inspection when the equipment is operating poorly.
If you cannot resolve a problem after inspecting the equipment, request repair at the retail outlet where the equipment was purchased.

Symptom	Possible Causes	Remedy
Starter motor does not start.	<ol style="list-style-type: none"> 1. Battery has a low charge. 2. Battery is deteriorated. 	<ol style="list-style-type: none"> 1. Recharge the battery. 2. Replace the battery.
Engine does not start.	<ol style="list-style-type: none"> 1. Fuel lever is "CLOSE". 2. No fuel 3. Emergency stop SW is "ON". 4. Terminal covers are opened. 5. Water or foreign material is mixed in with the fuel. 6. Blown fuse 	<ol style="list-style-type: none"> 1. Turn the fuel lever to "OPEN". 2. Add fuel. 3. Release Emergency stop SW. 4. Close the Terminal covers. 5. Drain water from and clean the fuel tank and fuel strainer. 6. Replace the fuse.
Engine starts but quickly stops.	<ol style="list-style-type: none"> 1. Insufficient oil 2. Overheating of water temperature 3. Battery recharging fault 	<ol style="list-style-type: none"> 1. Add oil. 2. Comply with rated outputs/Add cooling water. 3. Repair.
Black or white smoke is continuously exhausted from the muffler.	<ol style="list-style-type: none"> 1. Overloaded 	<ol style="list-style-type: none"> 1. Comply with the rated output.
Engine does not stop.	<ol style="list-style-type: none"> 1. Stop solenoid fault 	<ol style="list-style-type: none"> 1. Turn the fuel lever to "CLOSE" to stop the engine and repair.
No AC power output	<ol style="list-style-type: none"> 1. Breaker is "OFF" . 	<ol style="list-style-type: none"> 1. Turn the breaker to "ON" .
AC power output is weak.	<ol style="list-style-type: none"> 1. The current of devices using the equipment exceed the rated current. 	<ol style="list-style-type: none"> 1. Refer to "Usable Device Capacities" .

12. Engine Wiring Diagram

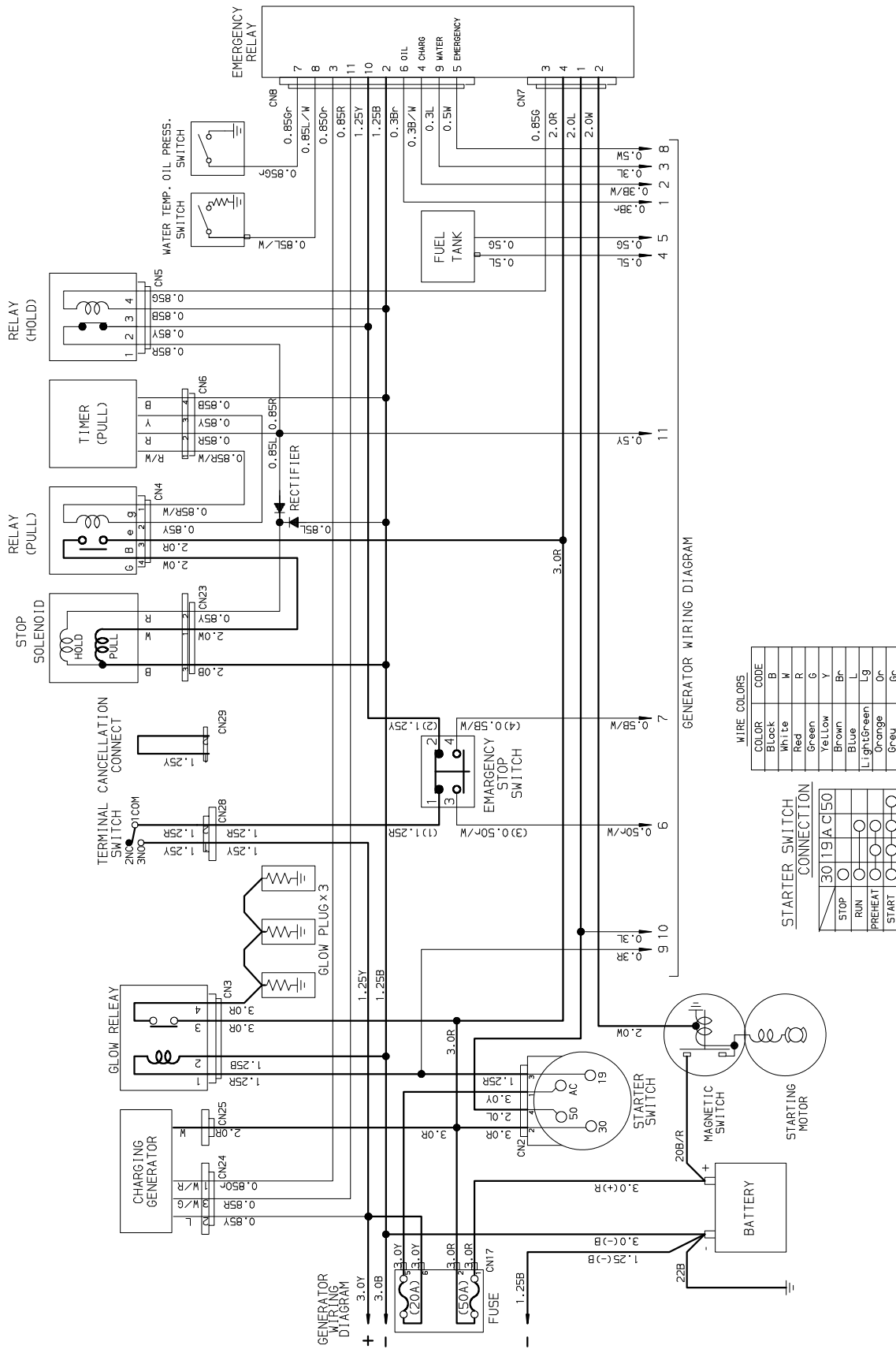

13. Generator Wiring Diagram

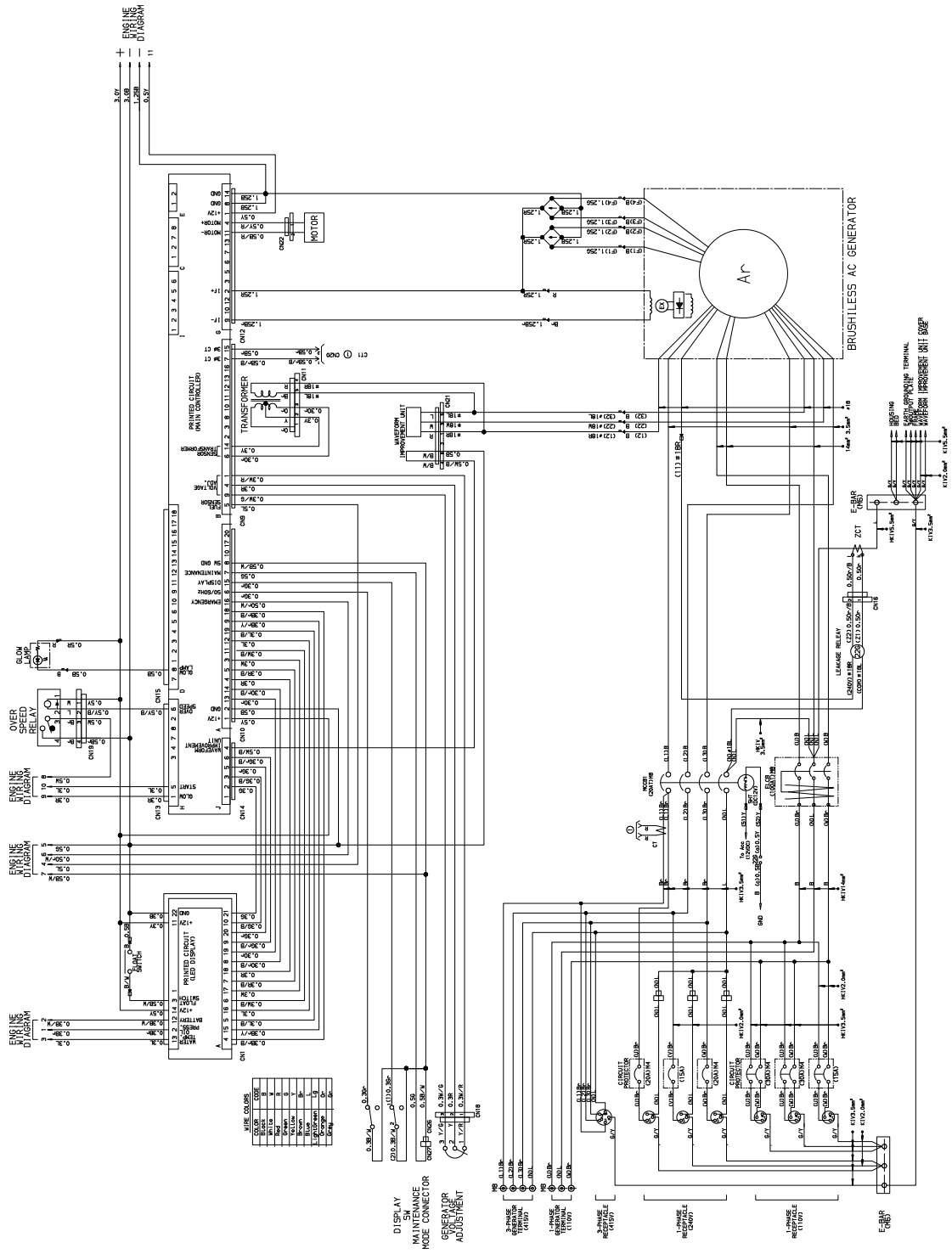



EXCLUSIVE DISTRIBUTER FOR UK & EIRE

SHINDAIWA LIMITED

**6 THE DELL
ENETRPISE DRIVE**

FOUR ASHES

Wolverhampton

WEST MIDLANDS

WV10 7DF

PHONE: 01902 791855, FAX: 01902 791933

WWW.SHINDAIWA.CO.UK